

AVNET EMBEDDED SPECIFICATION.

Datasheet HITACHI TX23D38VM0CPA

HITACHI

KAOSIUNG HITACHI ELECTRONICS CO., LTD.

FOR MESSRS: _____

DATE: Dec. 09th 2009

CUSTOMER'S ACCEPTANCE SPECIFICATIONS

TX23D38VM0CPA

Contents

No.	ITEM	SHEET No.	PAGE
1	COVER	7B64PS 2701-TX23D38VM0CPA-1	1-1/1
2	RECORD OF REVISION	7B64PS 2702-TX23D38VM0CPA-1	2-1/1
3	GENERAL DATA	7B64PS 2703-TX23D38VM0CPA-1	3-1/1
4	ABSOLUTE MAXIMUM RATINGS	7B64PS 2704-TX23D38VM0CPA-1	4-1/1
5	ELECTRICAL CHARACTERISTICS	7B64PS 2705-TX23D38VM0CPA-1	5-1/2~2/2
6	OPTICAL CHARACTERISTICS	7B64PS 2706-TX23D38VM0CPA-1	6-1/2~2/2
7	BLOCK DIAGRAM	7B64PS 2707-TX23D38VM0CPA-1	7-1/1
8	RELIABILITY TESTS	7B64PS 2708-TX23D38VM0CPA-1	8-1/1
9	LCD INTERFACE	7B64PS 2709-TX23D38VM0CPA-1	9-1/7~7/7
10	OUTLINE DIMENSIONS	7B63PS 2710-TX23D38VM0CPA-1	10-1/2~2/2
11	TOUCH PANEL	7B64PS 2711-TX23D38VM0CPA-1	11-1/2~2/2
12	APPEARANCE STANDARD	7B64PS 2712-TX23D38VM0CPA-1	12-1/4~4/4
13	PRECAUTIONS	7B64PS 2713-TX23D38VM0CPA-1	13-1/2~2/2
14	DESIGNATION OF LOT MARK	7B64PS 2714-TX23D38VM0CPA-1	14-1/1

ACCEPTED BY: _____

PROPOSED BY:

Elton Liu

2. RECORD OF REVISION

DATE	SHEET No.	SUMMARY

3. GENERAL DATA

3.1 DISPLAY FEATURES

This module is a 9" WVGA of 16:9 format amorphous silicon TFT. The pixel format is vertical stripe and sub pixels are arranged as R(red), G(green), B(blue) sequentially. This display is RoHS compliant, and COF (chip on film) technology and LED backlight are applied on this display.

Part Name	TX23D38VM0CPA
Module Dimensions	218.0(W) mm x 135.0(H) mm x 12.65 (D) mm
LCD Active Area	195.0(W) mm x 117.0(H) mm
Pixel Pitch	0.24375(W) mm x 0.24375(H) mm
Resolution	800 x 3(RGB)(W) x 480(H) dots
Color Pixel Arrangement	R, G, B Vertical stripe
LCD Type	Transmissive Color TFT; Normally Black
Display Type	Active Matrix
Number of Colors	16.7M Colors(6-bit + FRC)
Backlight	7 LEDs parallel x 3 serial (21 LEDs in total)
Weight	(415) g (typ.)
Interface	1ch-LVDS/Receiver ; 20 pins
Power Supply Voltage	3.3V for LCD; 12V for Backlight
Power Consumption	1.5 W for LCD (WVGA) ;6.96W for backlight
Viewing Direction	Super Wide Version (In Plane Switching)
Touch Panel	Resistive type; Film on Glass, 4-wire type; Antiglare surface

4. ABSOLUTE MAXIMUM RATINGS

Item	Symbol	Min.	Max.	Unit	Remarks
Supply Voltage	VDD	0	4.0	V	-
Input Voltage of Logic	VI	-0.3	VDD+0.3	V	Note 1
Operating Temperature	Top	-20	70	°C	Note 2
Storage Temperature	Tst	-30	80	°C	Note 2
Backlight Input Voltage	VLED	-	15	V	-

Note 1: The rating is defined for the signal voltages of the interface such as CLK, DE, Hsync, Vsync, and RGB data bus.

Note 2: The maximum rating is defined as above based on the temperature on the panel surface, which might be different from ambient temperature after assembling the panel into the application. Moreover, some temperature-related phenomenon as below needed to be noticed:

- Background color, contrast and response time would be different in temperatures other than 25°C.
- Operating under high temperature will shorten LED lifetime.

5. ELECTRICAL CHARACTERISTICS

5.1 LCD CHARACTERISTICS

$T_a = 25\text{ }^\circ\text{C}$, $V_{SS} = 0\text{V}$

Item	Symbol	Condition	Min.	Typ.	Max.	Unit	Remarks
Power Supply Voltage	VDD	-	3.0	3.3	3.6	V	-
Differential Input Voltage for LVDS Receiver Threshold	VI	"H" level	-	-	+100	mV	Note 1
		"L" level	-100	-	-		
DPS,FRC,AMODE Signal Input Voltage	VI	"H" level	0.7VDD	-	VDD	V	CMOS LEVEL
		"L" level	0	-	0.3VDD		
Power Supply Current	IDD	VDD-VSS =3.3V	-	485	580	mA	Note 2,3
Vsync Frequency	f_v	-	-	60	75	Hz	Note 4,5
Hsync Frequency	f_H	-	-	31.3	39.4	KHz	Note 4
DCLK Frequency	f_{CLK}	-	-	33.3	35	MHz	Note 4

Notes 1 : $V_{CM} = V_{DD} / 2V$

V_{CM} is common mode voltage of LVDS transmitter / receiver .The input terminal of LVDS transmitter is terminated with 100Ω .

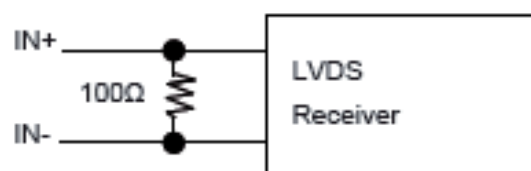

Notes 2 : $f_v = 60\text{Hz}$, $f_{CLK} = 35\text{MHz}$, $V_{DD} = 3.3\text{V}$, DC Current.

Typical value is measured when displaying vertical 256 gray scale. Maximum is measured when displaying Vertical-stripe.

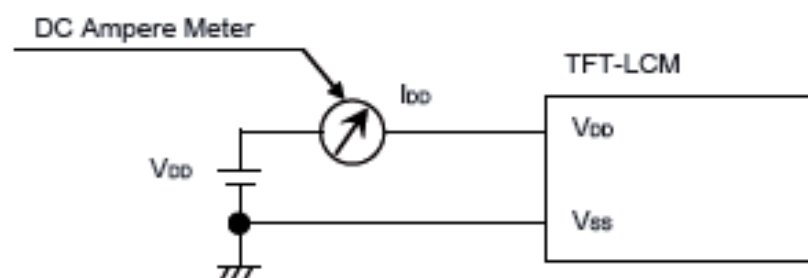

Notes 3 : As this module contains 1.0A fuse, prepare current source that is enough for cutting current fuse when a trouble happens. (larger than 2.5A)

Notes 4 : For LVDS Transmitter Input.

Notes 5 : Vertical frequency is recommended to apply 60Hz.

5.2 BACKLIGHT CHARACTERISTICS

Item	Symbol	Condition	Min.	Typ.	Max.	Unit	Remarks
LED Input Voltage	VLED	-	11.7	12.0	12.3	V	Note 1
LED Forward Current (Dim Control)	ILED	0V; 0% duty	540	580	620	mA	Note 2
		3.3VDC; 100% duty	15	30	45		
LED lifetime	-	580 mA	-	70K	-	hrs	Note 3

Note 1: As Fig. 5.1 shown, LED current is constant, 580 mA, controlled by the LED driver when applying 12V VLED.

Note 2: Dimming function can be obtained by applying DC voltage or PWM signal from the display interface CN1. The recommended PWM signal is 1K ~ 10K Hz with 3.3V amplitude.

Note 3: The estimated lifetime is specified as the time to reduce 50% brightness by applying 580 mA at 25°C.

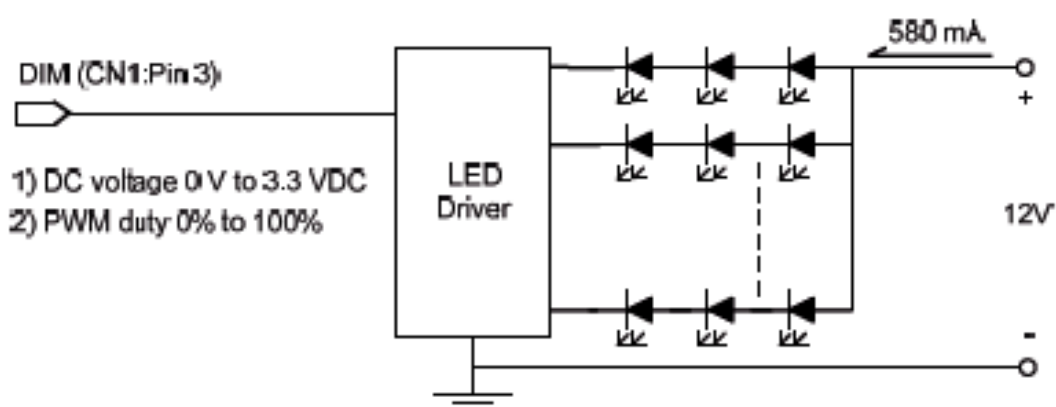

Fig. 5.1

6. OPTICAL CHARACTERISTICS

The optical characteristics are measured based on the conditions as below:

- Supplying the signals and voltages defined in the section of electrical characteristics.
- The backlight unit needs to be turned on for 30 minutes.
- The ambient temperature is 25°C.
- In the dark room around 500~1000 lx, the equipment has been set for the measurements as shown in Fig 6.1.

$T_a = 25\text{ }^\circ\text{C}$, $f_v = 60\text{ Hz}$, $V_{DD} = 3.3\text{ V}$

Item	Symbol	Condition	Min.	Typ.	Max.	Unit	Remarks	
Brightness of White	-	$\phi = 0^\circ, \theta = 0^\circ$, ILED= 580 mA	280	360	-	cd/m ²	Note 1	
Brightness Uniformity	-		75	-	-	%	Note 2	
Contrast Ratio	CR		500	800	-	-	Note 3	
Response Time	Rise + Fall	$\phi = 0^\circ, \theta = 0^\circ$	-	25	50	ms	Note 4	
NTSC Ratio	-	$\phi = 0^\circ, \theta = 0^\circ$	-	60	-	%	-	
Viewing Angle	θ_x	$\phi = 0^\circ, CR \geq 10$	-	85	-	Degree	Note 5	
	$\theta_{x'}$	$\phi = 180^\circ, CR \geq 10$	-	85	-			
	θ_y	$\phi = 90^\circ, CR \geq 10$	-	85	-			
	$\theta_{y'}$	$\phi = 270^\circ, CR \geq 10$	-	85	-			
Color Chromaticity	Red	X	$\phi = 0^\circ, \theta = 0^\circ$	0.59	0.64	0.69	-	Note 6
		Y		0.29	0.34	0.39		
	Green	X		0.31	0.36	0.41		
		Y		0.55	0.60	0.65		
	Blue	X		0.10	0.15	0.20		
		Y		0.01	0.06	0.11		
	White	X		0.30	0.35	0.40		
		Y		0.31	0.36	0.41		

Note 1: The brightness is measured from 9 point of the panel, P1~P9 in Fig. 6.2, for the average value.

Note 2: The brightness uniformity is calculated by the equation as below:

$$\text{Brightness uniformity} = \frac{\text{Min. Brightness}}{\text{Max. Brightness}} \times 100\%$$

, which is based on the brightness values of the 9 points measured by BM-5 as shown in Fig. 6.2.

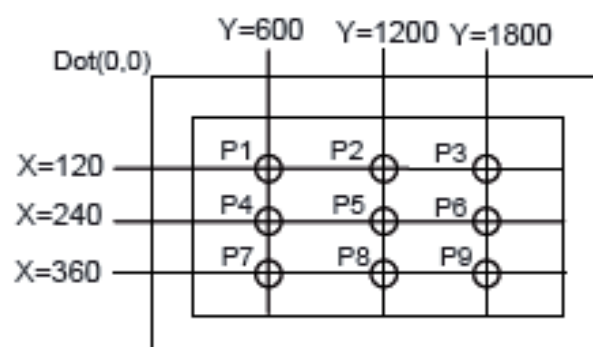
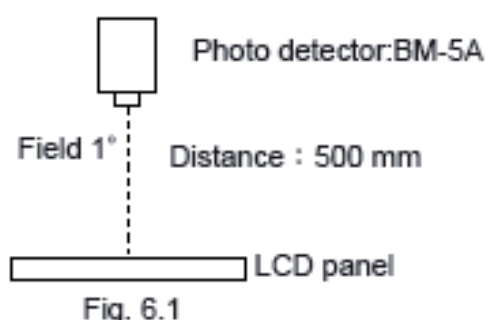

Note 3: The Contrast ratio is measured from the center point of the panel, P5, and defined as the following equation:

$$CR = \frac{\text{Brightness of White}}{\text{Brightness of Black}}$$

Note 4: The definition of response time is shown in Fig. 6.3. The rising time is the period from 10% brightness to 90% brightness when the data is from white to black. Oppositely, Falling time is the period from 90% brightness rising to 10% brightness.

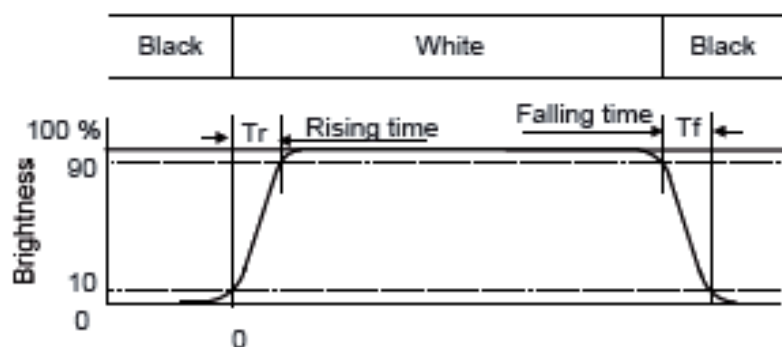

Fig. 6.3

Note 5: The definition of viewing angle is shown in Fig. 6.4. Angle ϕ is used to represent viewing directions, for instance, $\phi = 270^\circ$ means 6 o'clock, and $\phi = 0^\circ$ means 3 o'clock. Moreover, angle θ is used to represent viewing angles from axis Z toward plane XY.

The display is super wide viewing angle version; 85° viewing angle can be obtained from each viewing direction.

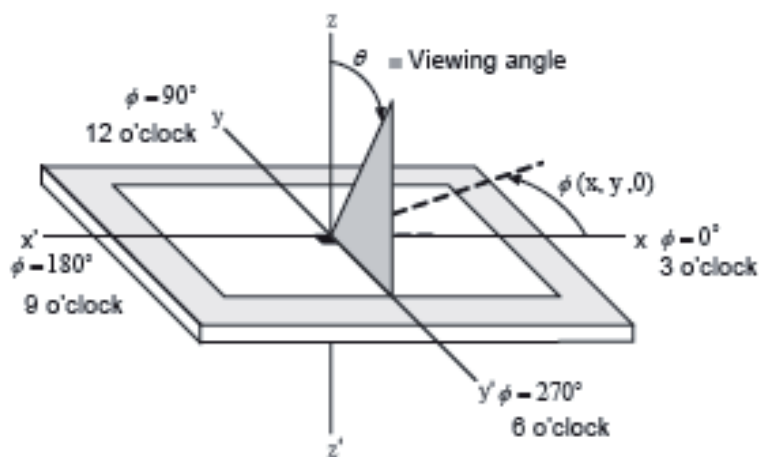
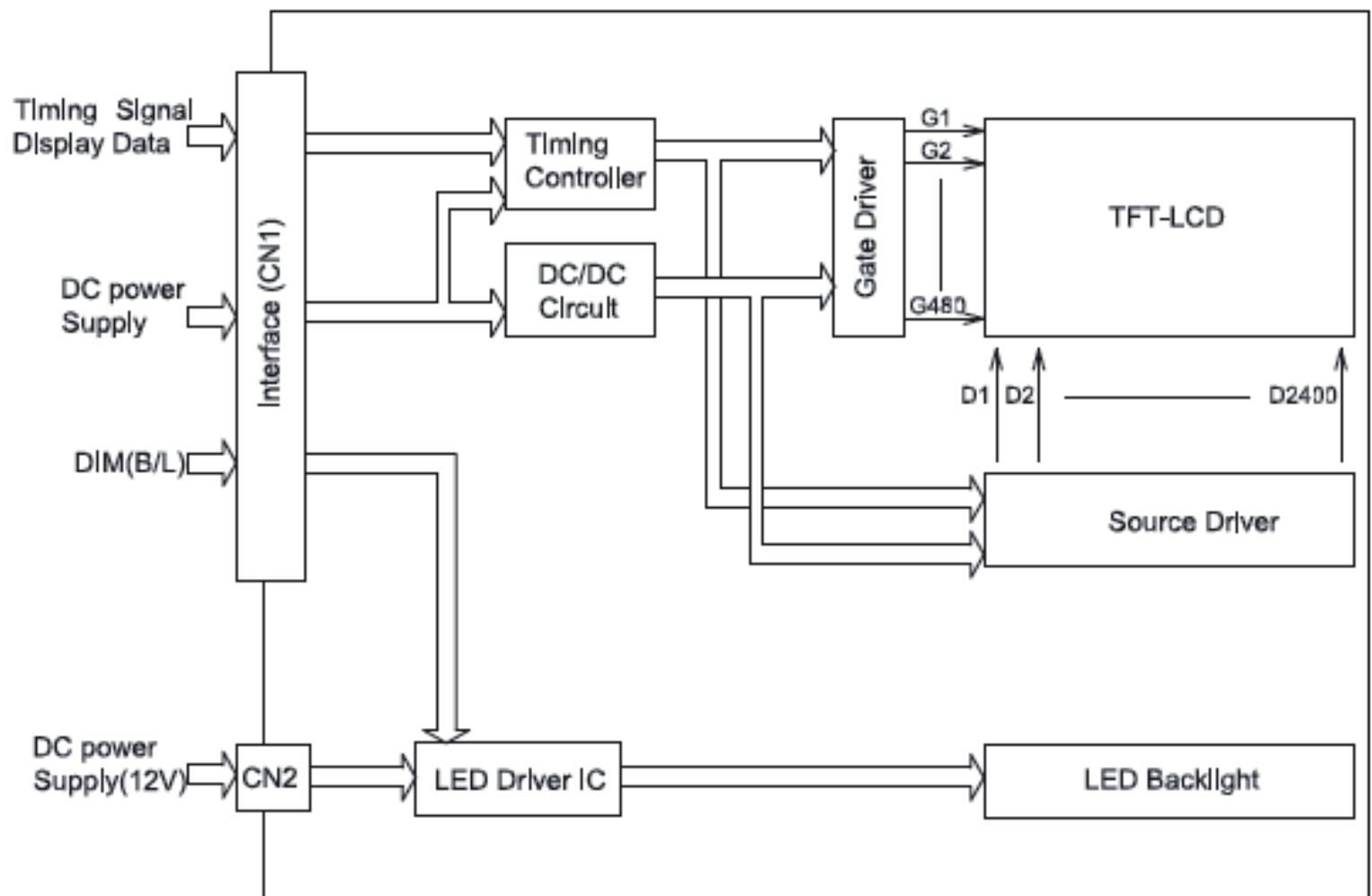

Fig. 6.4

Note 6: The color chromaticity is measured from the center point of the panel, P5, as shown in Fig. 6.2.

7 BLOCK DIAGRAM



8. RELIABILITY TESTS

Test Item	Condition	
High Temperature	1) Operating 2) 70°C	240 hrs
Low Temperature	1) Operating 2) -20°C	240 hrs
High Temperature	1) Storage 2) 80°C	240 hrs
Low Temperature	1) Storage 2) -30°C	240 hrs
Heat Cycle	1) Operating 2) -20°C ~70°C 3) 3hrs~1hr~3hrs	240 hrs
Thermal Shock	1) Non-Operating 2) -35°C ↔ 85°C 3) 0.5 hr ↔ 0.5 hr	240 hrs
High Temperature & Humidity	1) Operating 2) 40°C & 85%RH 3) Without condensation 4) Note 3	240 hrs
Vibration	1) Non-Operating 2) 20~200 Hz 3) 2G 4) X, Y, and Z directions	1 hr for each direction
Mechanical Shock	1) Non-Operating 2) 10 ms 3) 50G 4) ±X, ±Y and ±Z directions	Once for each direction
ESD	1) Operating 2) Tip: 200 pF, 250 Ω 3) Air discharge for glass: ± 8KV 4) Contact discharge for metal frame: ± 8KV	1) Glass: 9 points 2) Metal frame: 8 points

Note 1: Display functionalities are inspected under the conditions defined in the specification after the reliability tests.

Note 2: The display is not guaranteed for use in corrosive gas environments.

Note 3: Under the condition of high temperature & humidity, if the temperature is higher than 40°C, the humidity needs to be reduced as Fig. 8.1 shown.

Note 4: All pins of LCD interface(CN1) have been tested by ± 100V contact discharge of ESD under non-operating condition.

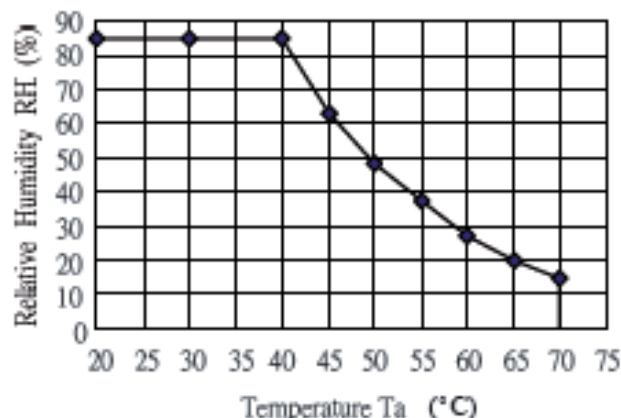

Fig. 8.1

9. LCD INTERFACE

9.1 INTERFACE PIN CONNECTIONS

The display interface connector is FI-SEB20P-HF13E made by JAE and more details of the connector are shown in the section of outline dimension.

Pin assignment of LCD interface is as below:

Pin No.	Symbol	Description	Note
1	VDD	Power Supply (typ.+3.3V)	Note 3
2	VDD		
3	DIM	Normal Brightness:0V or 0% PWM Duty Brightness Control:0V to 3.3VDC or 0% to 100% PWM Duty.	-
4	VSS	GND (0V)	Note 1
5	IN0-	Pixel Data	Note 2
6	IN0+		
7	VSS	GND (0V)	Note 1
8	IN1-	Pixel Data	Note 2
9	IN1+		
10	VSS	GND (0V)	Note 1
11	IN2-	Pixel Data	Note 2
12	IN2+		
13	VSS	GND (0V)	Note 1
14	CLK IN-	Clock	Note 2
15	CLK IN+		
16	VSS	GND (0V)	Note 1
17	IN3-	Pixel Data	Note 2
18	IN3+		
19	VSS	GND (0V)	Note 1
20	VSS		

Note 1: All VDD pins should be connected to +3.3V.

Note 2: All VSS pins should be connected to GND(0V),Metal bezel is connected internally to VSS.

Note 3: In n^- and n^+ ($n=0,1,2,3$),CLK IN- and CLK IN+ should be wired by twist-pairs or side by side FPC patterns, respectively.

The backlight interface connector is SM08B-SRSS-TB made by JST, and pin assignment of backlight is as below:

Pin No.	Signal	Level	Function
1~3	V _{LED+}	-	Power Supply for LED(12V)
4~5	NC	-	No Connection
6~8	V _{LED-}	-	GND

9.2 LVDS INTERFACE

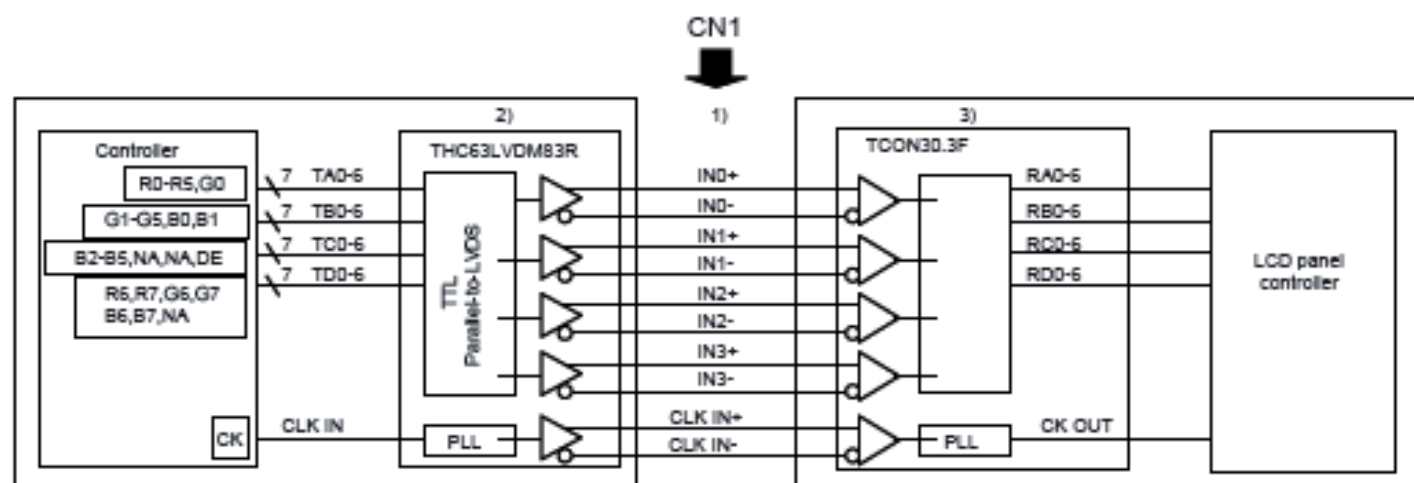

Note 1: 100Ω impedance of LVDS cable is recommended for best optical performance.

Note 2: Transmitter Made by Thine : THC63LVDM83R or equivalent.

Note 3: Receiver (TCON30.3-F) • Made by Thine : THC63LVDF84B equivalent.

9.3 DATA MAPPING

Pin No.	Pin name	Data	Pin No.	Pin name	Data
51	TA0	R0(LSB)	20	TC0	B2
52	TA1	R1	22	TC1	B3
54	TA2	R2	23	TC2	B4
55	TA3	R3	24	TC3	B5
56	TA4	R4	27	TC4	(NA)
3	TA5	R5	28	TC5	(NA)
4	TA6	G0(LSB)	30	TC6	DE
6	TB0	G1	50	TD0	R6
7	TB1	G2	2	TD1	R7(MSB)
11	TB2	G3	8	TD2	G6
12	TB3	G4	10	TD3	G7(MSB)
14	TB4	G5	16	TD4	B6
15	TB5	B0(LSB)	18	TD5	B7(MSB)
19	TB6	B1	25	TD6	(NA)

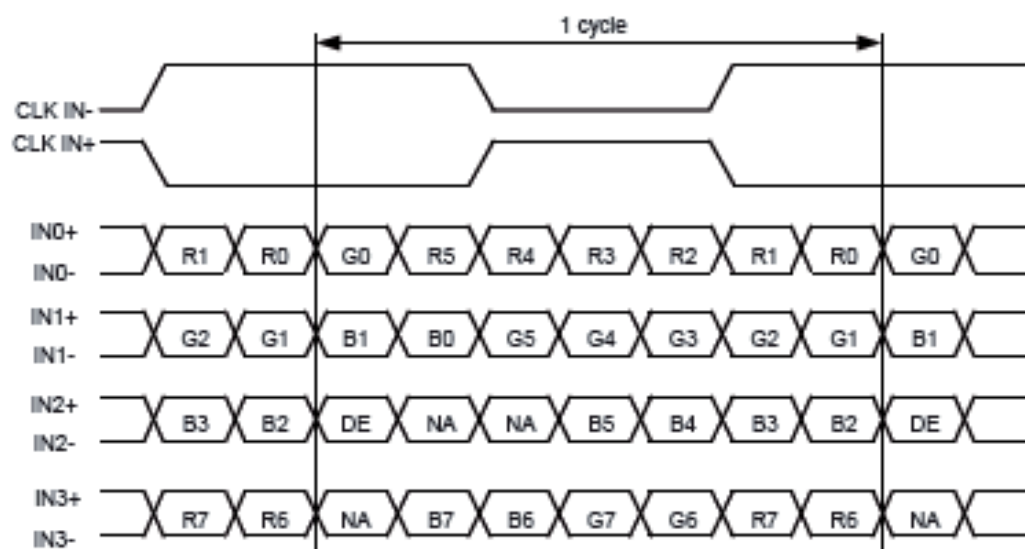

DE : Display Enable

NA : Not Available

9.4 DATA INPUT for DISPLAY COLOR(8BIT MODE)

Input color		Red Data								Green Data								Blue Data							
		R7	R6	R5	R4	R3	R2	R1	R0	G7	G6	G5	G4	G3	G2	G1	G0	B7	B6	B5	B4	B3	B2	B1	B0
		MSB				LSB				MSB				LSB				MSB				LSB			
Basic Color	Black	0	0	0	0	0	0	0	0	0	0	0	0	0	0	0	0	0	0	0	0	0	0	0	0
	Red(255)	1	1	1	1	1	1	1	1	0	0	0	0	0	0	0	0	0	0	0	0	0	0	0	0
	Green(255)	0	0	0	0	0	0	0	0	1	1	1	1	1	1	1	1	0	0	0	0	0	0	0	0
	Blue(255)	0	0	0	0	0	0	0	0	0	0	0	0	0	0	0	0	1	1	1	1	1	1	1	1
	Cyan	0	0	0	0	0	0	0	0	1	1	1	1	1	1	1	1	1	1	1	1	1	1	1	1
	Magenta	1	1	1	1	1	1	1	1	0	0	0	0	0	0	0	0	1	1	1	1	1	1	1	1
	Yellow	1	1	1	1	1	1	1	1	1	1	1	1	1	1	1	1	0	0	0	0	0	0	0	0
	White	1	1	1	1	1	1	1	1	1	1	1	1	1	1	1	1	1	1	1	1	1	1	1	1
Red	Black	0	0	0	0	0	0	0	0	0	0	0	0	0	0	0	0	0	0	0	0	0	0	0	
	Red(1)	0	0	0	0	0	0	0	1	0	0	0	0	0	0	0	0	0	0	0	0	0	0	0	
	Red(2)	0	0	0	0	0	0	1	0	0	0	0	0	0	0	0	0	0	0	0	0	0	0	0	
	:	:	:	:	:	:	:	:	:	:	:	:	:	:	:	:	:	:	:	:	:	:	:	:	
	:	:	:	:	:	:	:	:	:	:	:	:	:	:	:	:	:	:	:	:	:	:	:	:	
	Red(253)	1	1	1	1	1	1	0	1	0	0	0	0	0	0	0	0	0	0	0	0	0	0	0	
	Red(254)	1	1	1	1	1	1	1	0	0	0	0	0	0	0	0	0	0	0	0	0	0	0	0	
	Red(255)	1	1	1	1	1	1	1	1	0	0	0	0	0	0	0	0	0	0	0	0	0	0	0	
Green	Black	0	0	0	0	0	0	0	0	0	0	0	0	0	0	0	0	0	0	0	0	0	0	0	
	Green(1)	0	0	0	0	0	0	0	0	0	0	0	0	0	0	0	1	0	0	0	0	0	0	0	
	Green(2)	0	0	0	0	0	0	0	0	0	0	0	0	0	0	1	0	0	0	0	0	0	0	0	
	:	:	:	:	:	:	:	:	:	:	:	:	:	:	:	:	:	:	:	:	:	:	:	:	
	:	:	:	:	:	:	:	:	:	:	:	:	:	:	:	:	:	:	:	:	:	:	:	:	
	Green(253)	0	0	0	0	0	0	0	0	1	1	1	1	1	1	0	1	0	0	0	0	0	0	0	
	Green(254)	0	0	0	0	0	0	0	0	1	1	1	1	1	1	0	0	0	0	0	0	0	0	0	
	Green(255)	0	0	0	0	0	0	0	0	1	1	1	1	1	1	1	0	0	0	0	0	0	0	0	
Blue	Black	0	0	0	0	0	0	0	0	0	0	0	0	0	0	0	0	0	0	0	0	0	0	0	
	Blue(1)	0	0	0	0	0	0	0	0	0	0	0	0	0	0	0	0	0	0	0	0	0	0	1	
	Blue(2)	0	0	0	0	0	0	0	0	0	0	0	0	0	0	0	0	0	0	0	0	0	0	1	
	:	:	:	:	:	:	:	:	:	:	:	:	:	:	:	:	:	:	:	:	:	:	:	:	
	:	:	:	:	:	:	:	:	:	:	:	:	:	:	:	:	:	:	:	:	:	:	:	:	
	Blue(253)	0	0	0	0	0	0	0	0	0	0	0	0	0	0	0	1	1	1	1	1	1	1	0	
	Blue(254)	0	0	0	0	0	0	0	0	0	0	0	0	0	0	0	1	1	1	1	1	1	1	0	
	Blue(255)	0	0	0	0	0	0	0	0	0	0	0	0	0	0	0	1	1	1	1	1	1	1	1	

Note 1: Definition of gray scale : Color(n) Number in parenthesis indicates gray scale level. Larger number corresponds to brighter level.

Note 2: Data Signal : 1 : High, 0 : Low

9.5 INTERFACE TIMING

(1) LVDS Receiver Timing

(Interface of TFT module)

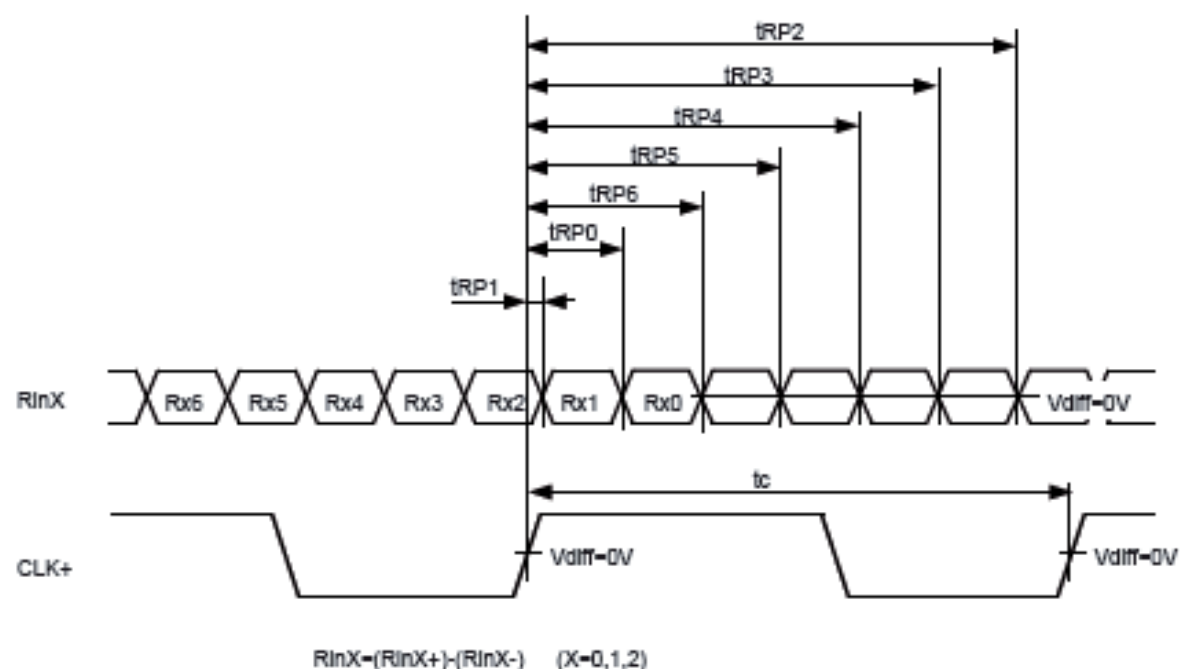

Item	Symbol	Min.	Typ.	Max.	Unit	
DCLK	FREQUENCY	$1/t_c$	25.0	28.0 1) 33.3 2)	35.0	MHz
R_{inX} ($X=0,1,2$)	0 data position	t_{RP0}	$1/7t_{CLK}-0.65$	$1/7^*t_{CLK}$	$1/7t_{CLK}+0.65$	ns
	1st data position	t_{RP1}	-0.65	0	-0.65	
	2nd data position	t_{RP2}	$6/7t_{CLK}-0.65$	$6/7^*t_{CLK}$	$6/7t_{CLK}+0.65$	
	3rd data position	t_{RP3}	$5/7t_{CLK}-0.65$	$5/7^*t_{CLK}$	$5/7t_{CLK}+0.65$	
	4th data position	t_{RP4}	$4/7t_{CLK}-0.65$	$4/7^*t_{CLK}$	$4/7t_{CLK}+0.65$	
	5th data position	t_{RP5}	$3/7t_{CLK}-0.65$	$3/7^*t_{CLK}$	$3/7t_{CLK}+0.65$	
	6th data position	t_{RP6}	$2/7t_{CLK}-0.65$	$2/7^*t_{CLK}$	$2/7t_{CLK}+0.65$	

Note 1: $f_v=50\text{Hz}$

Note 2: $f_v=60\text{Hz}$

(2) Timing converter timing

(Input timing for transmitter)

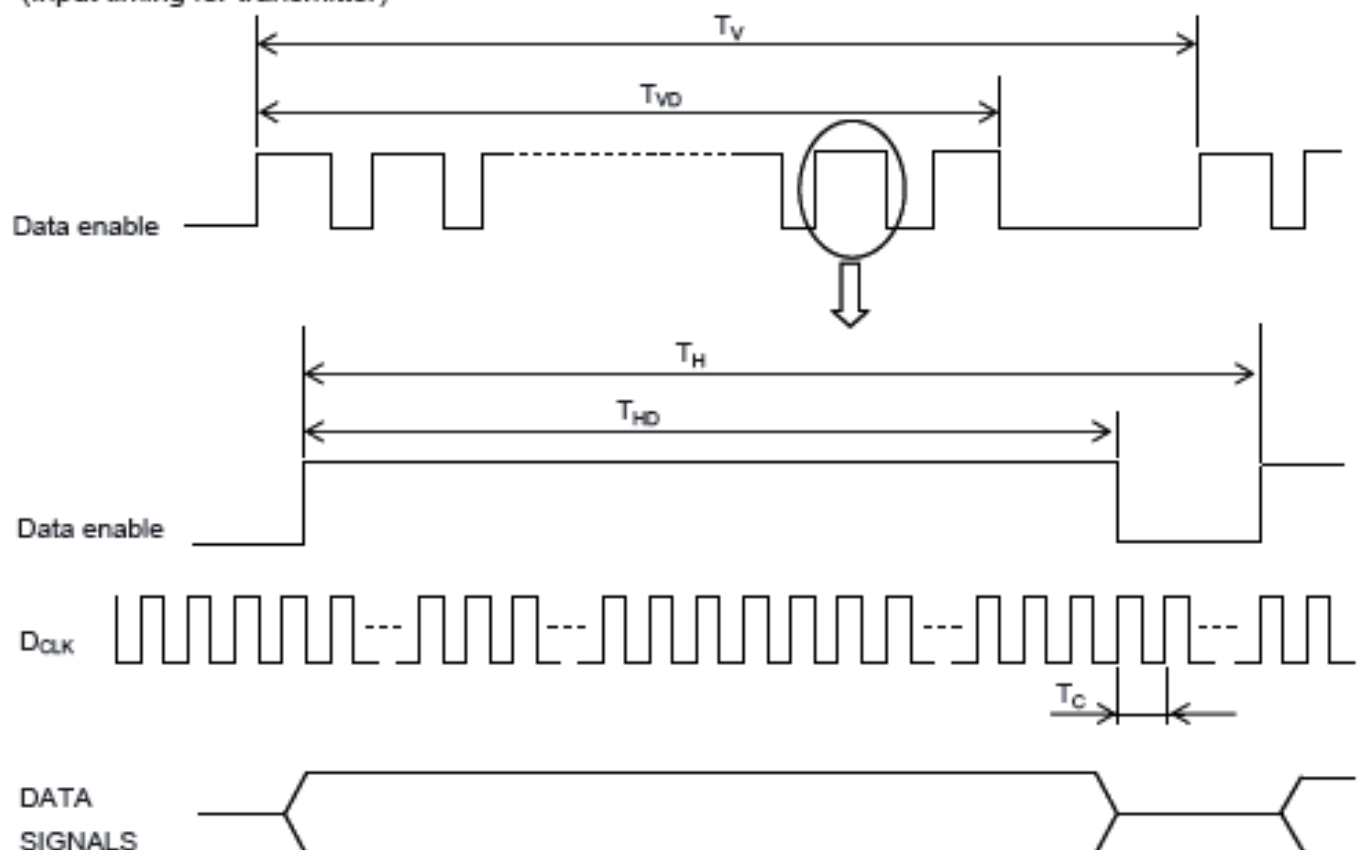

The timings except mentioned above are referred to the specifications of your transmitter.

Item		Symbol	Min.	Typ.	Max.	Unit	Remarks
DCLK	Cycle time	T_C	28.6	30.0	35.7	ns	
Data Enable	Duty	D	0.45	0.5	0.5	-	
	Horizontal period	T_H	842	1056	1056	T_C	
	Horizontal width-Active	T_{HD}	800	800	800	T_C	
	Vertical period	T_V	482	525	525	T_H	
	Vertical width-Active	T_{VD}	480	480	480	T_H	
	Frame frequency	f_V	42	60	50	H_z	

(3) TIMING BETWEEN INTERFACE SIGNAL AND POWER SUPPLY

Power Supply, Input Signal and Backlight Voltage ON/OFF/REENTRY should comply with the following sequence.

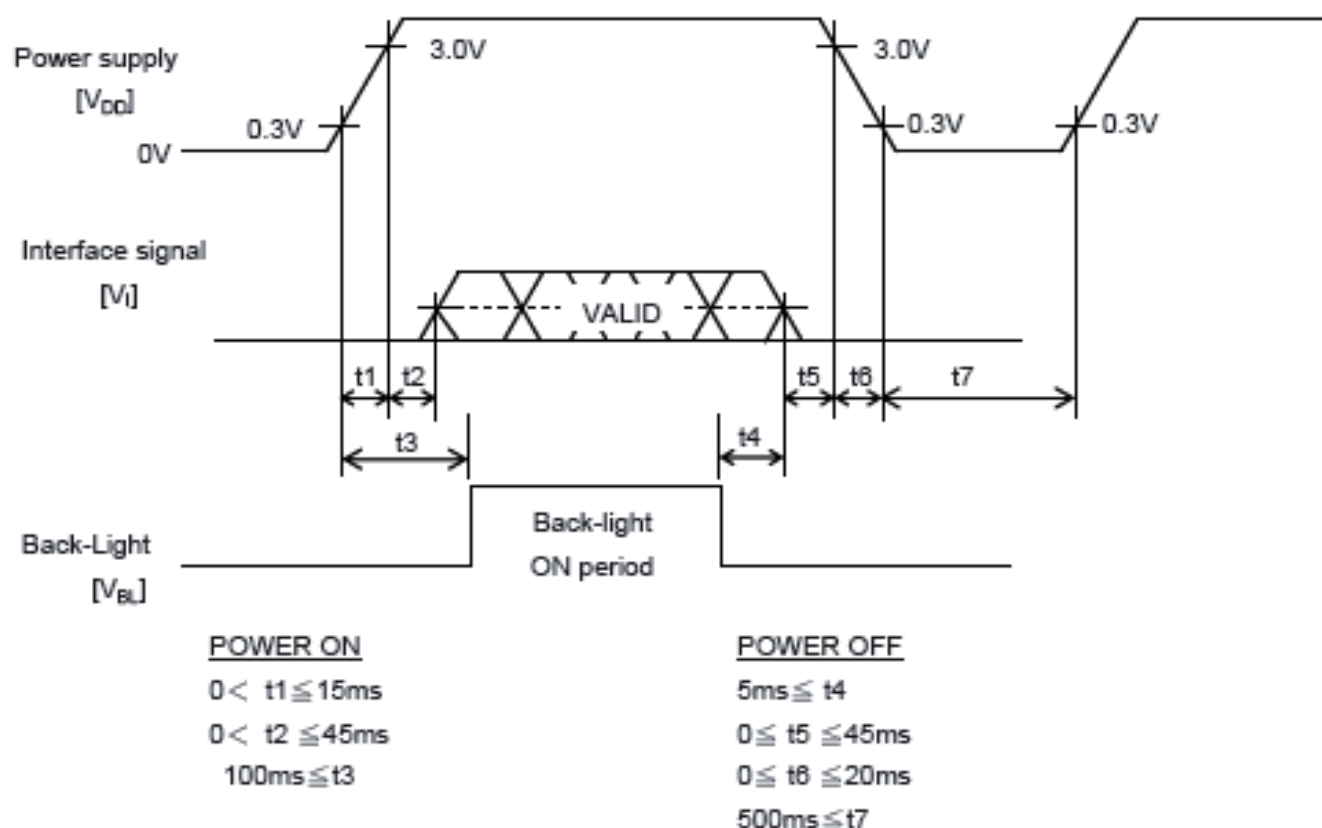

Note 1: In order to prevent electronic parts from destruction caused by latch-up, please input signal after Power Supply Voltage ON. In addition, please turn off signals before power supply voltage OFF.

Note 2: In order to prevent from function error due to residual charge, please reenter power supply voltage after time stipulated with t7.

Note 3: Please turn on Backlight after signals fix and turn off before signals down, otherwise noise appears in the display. The noise cause no problem with display performance in case of timing sequence comply with the spec.

10.2 BACK SIDE

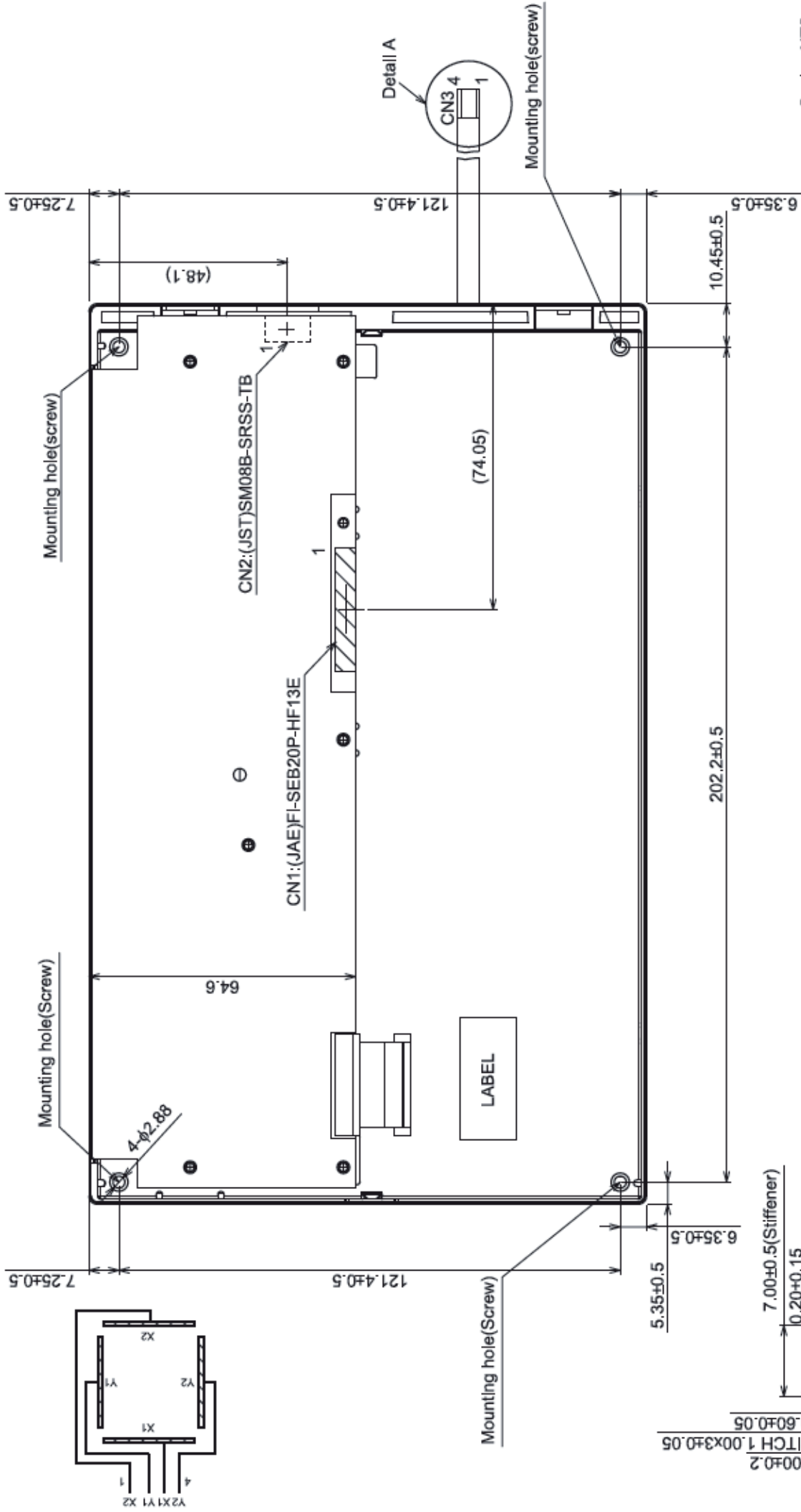

Scale : NTS
Unit : mm

Note 1: The maximum depth of mounting pillars is 3.3mm.

11. TOUCH PANEL

The type of touch panel used on this display is resistive, analog, 4-wire and film on glass, and more characteristics are shown as below:

11.1 OPERATING CONDITIONS

Item	Specification	Remarks
Operating Voltage	DC 5V	DC 7V Max.
Operating Current	20mA	-

11.2 ELECTRICAL CHARACTERISTICS

Item	Specification	Remarks
Circuit resistance	X- axis	370~1010 Ω
	Y-axis	200~590 Ω
Insulation Resistance	X-Y	>20MΩ
Linearity	X	$\leq \pm 1.5\%$
	Y	$\leq \pm 1.5\%$
Chattering	$\leq 10\text{ms}$	-

Note 1: The test conditions and equipments of linearity are as below:

- Material of pen: poly-acetal resin
- End shape: R 0.8 mm
- Test force: 150 gf
- Pitch: 10 mm
- Test area is shown in Fig. 11.1

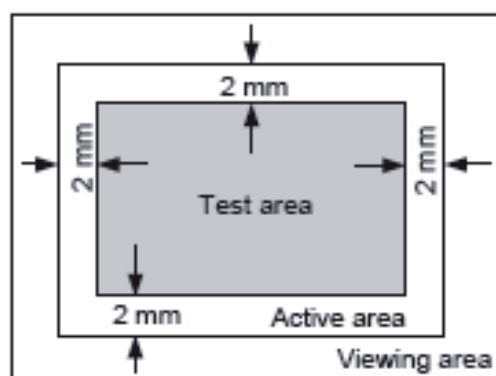

Fig. 11.1

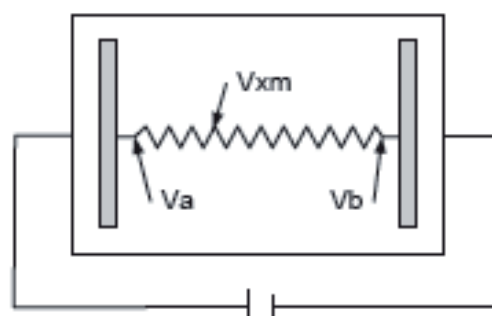

Fig. 11.2

As shown in Fig. 11.2, applying voltage meter to measure V_a , V_b and V_{xm} , where V_a is the maximum voltage in the active area; V_b is the minimum voltage in the active area; V_{xm} is the measured voltage of point x selected by random. Afterwards, the linearity can be calculated by following equation:

$$\text{Linearity} = \frac{|V_{xi} - V_{xm}|}{V_a - V_b} \times 100\%$$

where V_{xi} is the idea voltage of point x.

The method to measure the linearity of Y-axis is the same as above.

11.3 MECHANICAL CHARACTERISTICS

Item		Specification	Remarks
Activation force	Finger	1.2N Max	End shape: R8.0 mm
	Pen	1.2N Max	End shape: R0.8 mm
Surface Hardness		3H	JIS K 5400

11.4 OPTICAL CHARACTERISTICS

Item	Specification	Remarks
Transmittance	>80%	-

11.5 SAFETY AND ATTENTIONS

- 1) Do not put heavy shock or stress on the touch panel.
- 2) Please use soft cloth or absorbent cotton with ethanol to clean the touch panel by gently wiping. Moreover, please wipe it by horizontal or vertical direction instead of circling to prevent leaving scars on the touch panel's surface.
- 3) Do not use any harmful chemicals such as acetone, toluene, and isopropyl alcohol to clean the display's surface.

12. APPEARANCE STANDARD

The appearance inspection is performed in a dark room around 1200 lx based on the conditions as below:

- The distance between inspector's eyes and display is 30 cm.
- The viewing zone is defined with angle θ shown in Fig. 12.1 The inspection should be performed within 45° when display is shut down. The inspection should be performed within 5° when display is power on.

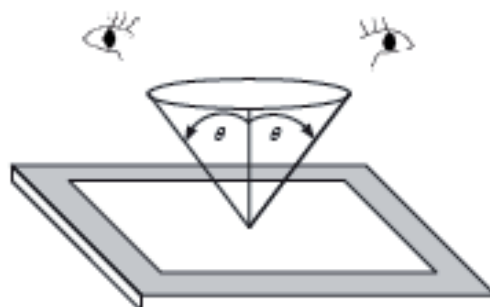

Fig. 12.1

12.1 THE DEFINITION OF LCD ZONE

LCD panel is divided into 3 areas as shown in Fig.12.2 for appearance specification in next section. A zone is the LCD active area (dot area); B zone is the area, which extended 1 mm out from LCD active area; C zone is the area between B zone and metal frame.

In terms of housing design, B zone is the recommended window area customers' housing should be located in.

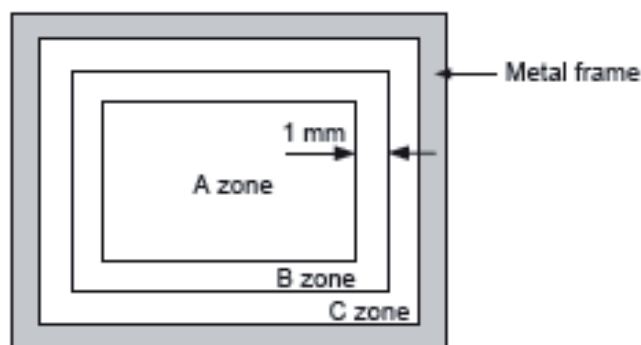

Fig. 12.2

12.2 LCD APPEARANCE SPECIFICATION

When displaying conditions are not stable (ex. at turn on or off), the following specifications are not applied.

Operating inspection

No	Item			Max. acceptable number	Unit	Remarks
				A-ZONE		
1	Dot defect	Sparkle mode	1-dot	2	pcs	Note 1,2,4
			2-dots	1	Units	Note 1,2,5
			3-dots	not allowed		
			Total	2	Units	Note 1,2
		Black mode	1-dot	3	pcs	Note 1,3,4
			2-dots	2	Units	Note 1,3,5
			3-dots	not allowed		
		Total	3	Units	Note 1,3	
		Total	Density	1	Units/φ80mm	Note 1,2,3,6
			Total	3	Units	Note 1
2	Line defect			Serious one is not allowed	-	-
3	Uneven brightness					
4	Stain inclusion Line shape W : width (mm) L : length (mm)	W ≤ 0.02	L : Ignore	Ignore	pcs	Note 7
		W ≤ 0.03	L ≤ 2.0	10		
			L > 2.0	0		
		W ≤ 0.06	L ≤ 1.0	10		
			L > 1.0	0		
W > 0.06	-	(See dot shape)				
5	Stain inclusion Dot shape D : ave. dia (mm)	D ≤ 0.22		Ignore	pcs	Note 7
		D ≤ 0.33		5		
		D > 0.33		0		
6	Scratch on polarizer Line shape W : width (mm) L : length (mm)	W ≤ 0.01	L : Ignore	Ignore	pcs	Note 8
		W ≤ 0.02	L ≤ 40	10		
			L > 40	0		
		W ≤ 0.04	L ≤ 20	10		
			L > 20	0		
7	Scratch on polarizer Dot shape D : ave. dia (mm)	D ≤ 0.2		Ignore	pcs	Note 8
		D ≤ 0.4		10		
		D > 0.4		0		

Non-operating inspection

No	ITEM	Max. acceptable number		Unit	Remarks
		A-zone			
8	Bubbles, peeling In polarizer (D:ave.dia(mm))	$D \leq 0.3$	Ignore	pcs	Note 8
		$D \leq 0.5$	10		
		$D \leq 1.0$	5		
		$D > 1.0$	0		
9	Wrinkles on polarizer	Serious one is not allowed		-	-

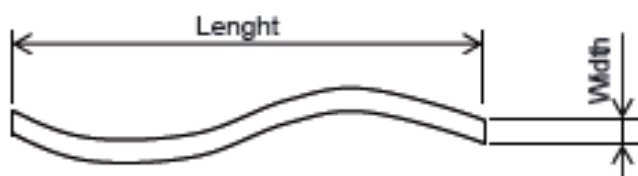
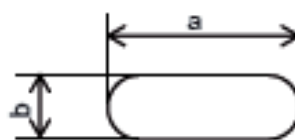

Fig 12.3



$$\text{Average diameter} = \frac{a+b}{2}$$

Fig 12.4

Note 1: Dot defect : defect area > 1/2 dot

Note 2: Sparkle mode : brightness of dot is more than 30% at black raster.

Note 3: Black mode : brightness of dot is less than 70% at white raster.

Note 4: 1 dot : defect dot is isolated, not attached to other defect dot.

Note 5: N dots : N defect dots are consecutive. (N means the number of defects dots)

Note 6: Density : number of defect dots inside 20mm ϕ .

Note 7: Those stains which can be wiped out easily are acceptable.



Note 8: Polarizer area inside of B-zone is not applied.

12.3 TOUCH PANEL APPEARANCE SPECIFICATION

The specification as below is defined by the amount of unexpected material in different zones of touch panel.

Item	Criteria			Applied zone
Scratches	Width (mm)	Length (mm)	Maximum number	A, B
	$W > 0.1$	$L \geq 10$	Not allowed	
	$0.10 > W \geq 0.05$	$L < 10$	4 pcs max.	
	$0.05 \geq W$	$L < 10$	Ignored	
Foreign Materials	Filamentous (Line shape)			A, B
	Width (mm)	Length (mm)	Maximum number	
	$W > 0.10$	-	Dust (circular)	
	$0.10 \geq W > 0.05$	$3 < L$	Not allowed	
	$0.05 \geq W$	$L \leq 3$	Ignored	
	Round (Dot shape)			A, B
	Average diameter (mm)		Maximum number	
	$D > 0.3$		Not allowed	
	$0.3 \geq D > 0.2$		3 pcs max.	
	$D \leq 0.2$		Ignored	A, B

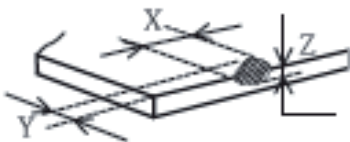
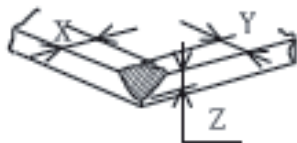
The limitation of glass flaw occurred on touch panel is defined in the table as below.

Item	Specifications	
Edge flaw		$X \leq 5.0 \text{ mm}$ $Y \leq 1.0 \text{ mm}$ $Z \leq \text{Thickness}$
Corner flaw		$X \leq 3.0 \text{ mm}$ $Y \leq 3.0 \text{ mm}$ $Z \leq \text{Thickness}$
Progressive flaw		Not allowed

13. PRECAUTIONS

13.1 PRECAUTIONS of TOUCH PANEL

1) Please refer to Fig. 13.1 for housing the display with touch panel into applications. The Fig. 13.1 shows some points as below:

- The cushion needs to be designed between housing and touch panel in order to avoid unexpected pressure to cause any wrong reactions, and the cushion should be located in the cushion area.
- The housing should not cover the active area of touch panel as the figure shown.

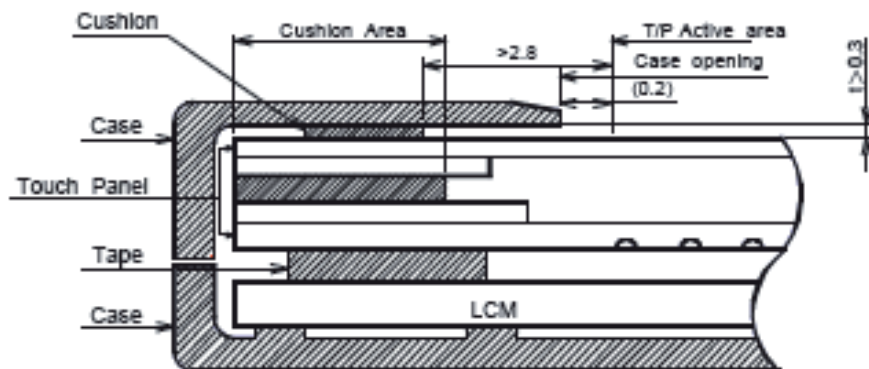

Fig. 13.1

13.2 PRECAUTIONS of ESD

- 1) Before handling the display, please ensure your body has been connected to ground to avoid any damages by ESD. Also, do not touch display's interface directly when assembling.
- 2) Please remove the protection film very slowly before turning on the display to avoid generating ESD.

13.3 PRECAUTIONS of HANDLING

- 1) In order to keep the appearance of display in good condition, please do not rub any surfaces of the displays by using sharp tools harder than 3H, especially touch panel, metal frame and polarizer.
- 2) Please do not stack the displays as this may damage the surface. In order to avoid any injuries, please avoid touching the edge of the glass or metal frame and wore gloves during handling.
- 3) Touching the polarizer or terminal pins with bare hand should be avoided to prevent staining and poor electrical contact.
- 4) Do not use any harmful chemicals such as acetone, toluene, and isopropyl alcohol to clean display's surfaces.
- 5) Please use soft cloth or absorbent cotton with ethanol to clean the display by gently wiping. Moreover, when wiping the display, please wipe it by horizontal or vertical direction instead of circling to prevent leaving scars on the display's surface, especially polarizer.
- 6) Please wipe any unknown liquids immediately such as saliva, water or dew on the display to avoid color fading or any permanent damages.
- 7) Maximum pressure to the surface of the display must be less than 1.96×10^4 Pa. If the area of applied pressure is less than 1 cm^2 , the maximum pressure must be less than 1.96N.

13.4 PRECAUTIONS of STORAGE

If the displays are going to be stored for years, please be aware the following notices.

- 1) Please store the displays in a dark room to avoid any damages from sunlight and other sources of UV light.
- 2) The recommended long term storage temperature is between 10 C° ~35 C° and 55%~75% humidity to avoid causing bubbles between polarizer and LCD glasses, and polarizer peeling from LCD glasses.
- 3) It would be better to keep the displays in the container, which is shipped from Hitachi, and do not unpack it.
- 4) Please do not stick any labels on the display surface for a long time, especially on the polarizer.

14. DESIGNATION of LOT MARK

1) The lot mark is showing in Fig.13.1. First 4 digits are used to represent production lot, T represented made in Taiwan, and the last 6 digits are the serial number.

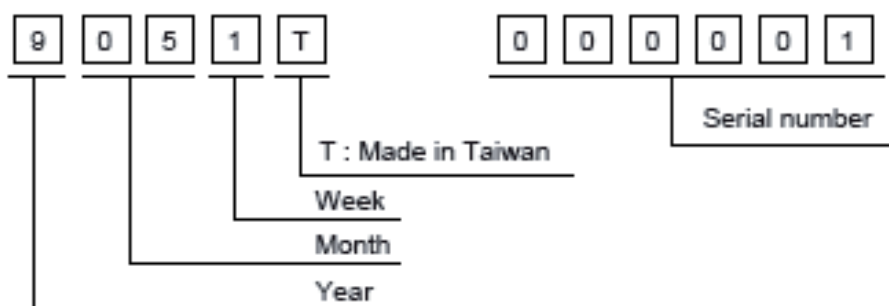

2) The tables as below are showing what the first 4 digits of lot mark are shorted for.

Year	Mark
2009	9
2010	0
2011	1
2012	2
2013	3

Month	Mark	Month	Mark
1	01	7	07
2	02	8	08
3	03	9	09
4	04	10	10
5	05	11	11
6	06	12	12

Week (Days)	Mark
1~7	1
8~14	2
15~21	3
22~28	4
29~31	5

3) Except letters I and O, revision number will be shown on lot mark and following letters A to Z.

4) The location of the lot mark is on the back of the display shown in Fig. 14.1.



Fig 14.1

AVNET EMBEDDED OFFICES.

DENMARK

Trident
Avnet Nortec A/S
Ellekær 9
2730 Herlev
Phone: +45 3678 6250
Fax: +45 3678 6255
denmark@avnet-embedded.eu

FINLAND

Trident
Avnet Nortec Oy
Tiilenpolttajankuja 3 A B
1720 Vantaa
Phone: +358 207 499260
Fax: +358 942 597446
finland@avnet-embedded.eu

FRANCE

Axess Technology
Avnet EMG France SA
Immeuble 154, Parc Chene 2
5, allée du General Benoist
69000 Bron
Phone: +33 4 72 81 02 30
Fax: +33 4 72 81 02 34
axess-bron@avnet-embedded.eu

Axess Technology
Avnet EMG France SA
4, rue de la Couture
Bâtiment Milan, BP 20209
94518 Rungis Cedex
Phone: +33 1 49 78 88 88
Fax: +33 1 49 78 88 89
axess-rungis@avnet-embedded.eu

Axess Technology
Avnet EMG France SA
ZA la Hallerais le Semiramis
35770 Vern sur Seiche
Phone: +33 2 99 77 37 02
Fax: +33 2 99 77 33 38
axess-rennes@avnet-embedded.eu

GERMANY (AUSTRIA, CZECH REPUBLIC, HUNGARY, POLAND, SWITZERLAND)

Avnet Embedded
Avnet EMG GmbH
Gruber Straße 60c
85586 Poing
Phone: +49 8121 775 500
Fax: +49 8121 775 550
poing@avnet-embedded.eu

Avnet Embedded
Avnet EMG GmbH
Lötscher Weg 66
41334 Nettetal
Phone: +49 8121 775 500
Fax: +49 8121 775 550
nettetal@avnet-embedded.eu

ITALY

Avnet Embedded
Avnet EMG Italy SRL
Via Manzoni, 44
20095 Cusano Milanino
Phone: +39 02 66092 1
Fax: +39 02 66092 498
milano@avnet-embedded.eu

NETHERLANDS (BELGIUM, LUXEMBOURG)

Avnet Embedded
Avnet B.V.
Takkebijsters 2
4802 BL Breda
Phone: +31 76 5722400
Fax: +31 76 5722404
benelux@avnet-embedded.eu

SPAIN

Avnet Embedded
Avnet Iberia SA
C/Chile, 10 - Edificio Madrid 92
28290 Las Matas (Madrid)
Phone: +34 91 372 7142
Fax: +34 91 636 9788
madrid@avnet-embedded.eu

SWEDEN (NORWAY)

Trident
Avnet Nortec AB
Esplanaden 3 D
172 67 Sundbyberg
Phone: +46 8 564 725 50
Fax: +46 8 760 01 10
sweden@avnet-embedded.eu

UNITED KINGDOM (IRELAND)

TDC
Avnet EMG Ltd.
Pilgrims Court, 15/17 West Street
Reigate, Surrey, RH2 9BL
Phone: +44 1737 227888
Fax: +44 1737 243872
tdc@avnet-embedded.eu

Trident
Avnet EMG Ltd.
Pilgrims Court, 15/17 West Street
Reigate, Surrey, RH2 9BL
Phone: +44 1737 227800
Fax: +44 1737 244698
trident-uk@avnet-embedded.eu

All trademarks and logos are the property of their respective owners. This document provides a brief overview only and is not intended to be complete or binding offer. Product information, including information related to a product's specifications, uses or conformance with legal or other requirements, is obtained by Avnet from its suppliers or other sources deemed reliable and is provided by Avnet on an "As Is" basis. Avnet makes no representation as to the accuracy or completeness of the product information and Avnet disclaims all representations, warranties and liabilities under any theory with respect to the product information, including any implied warranties of merchantability, fitness for a particular purpose, title and/or non-refrangement. All product information is subject to change without notice.

LOCAL AVNET EMBEDDED BUSINESSES:

axess
technology

An Avnet Embedded Business

tdc

An Avnet Embedded Business

trident

An Avnet Embedded Business