

Panasonic
ideas for life

**FOR CELLULAR PHONE;
ULTRA LOW PROFILE TYPE
FOR PORTABLE EQUIPMENT
(0.5mm PITCH)**

**SYSTEM CONNECTORS
ULTRA-LOW PROFILE TYPE (AXR3)
I/O CONNECTORS FOR
PORTABLE EQUIPMENT (AXR5)**

System connector ultra low profile type
Receptacle
18, 22 and 24 contacts



I/O connectors for portable equipment
Receptacle
18, 22, 24 and 26 contacts



50 contacts



System connector ultra low profile type
Plug (cable connection type)
18, 22, 24 and 26 contacts



I/O connectors for portable equipment
Plug (cable connection type)
50 contacts



System connector ultra low profile type
Plug (Board mounting type)
22, 26 and 50 contacts

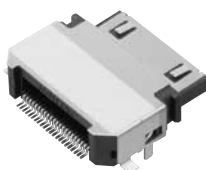

FEATURES

1. Compact receptacle helps to design lighter, slimmer, smaller devices.

1) Super low-profile type system connector.

- Board cutting type

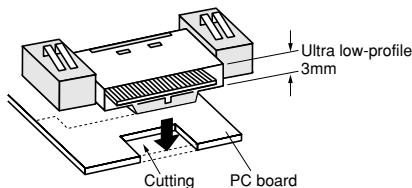

- On board mounting type

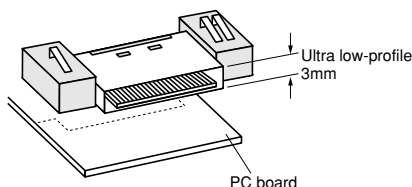

2) I/O connector for portable equipment
• 18, 22, 24 and 26 contacts

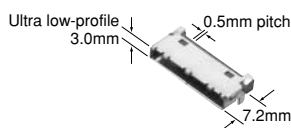

- 50 contacts

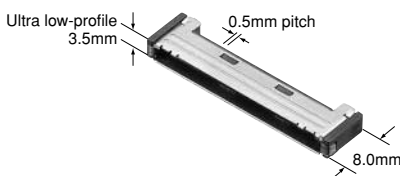

2. Bellows-type contacts

Our bellows-type contacts resist mating stress and offer high contact reliability.

The bellows type contacts are fabricated by bending thin sheet metal. They offer reliable contact since a rounded corner, instead of a sharp edge, is used for tuning fork type contact.



3. Coaxial portion with switching function (1 Form B configuration) can be applied up to 2GHz.

4. Connection of incorrect pairs is prevented by cross-manufacturer mating error prevention key.

By changing the location of the mating error prevention key, erroneous insertion of a different connector is prevented. This eliminates the chance of any problems that may be caused by mistaken connections. Please consult us for more information.

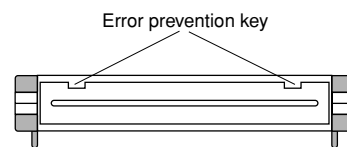

The key groove is different for every customer.

5. Plugs with 22, 26 and 50 contacts are also available in board mounting types. These are ideal for such applications as the connection between PDAs and data-communication cradles.

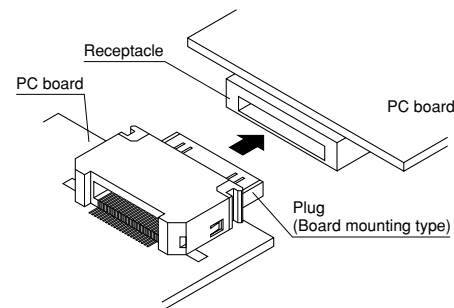

6. Compliance with RoHS' Directive
Environmentally friendly, the connectors' comply with Europe's RoHS' Directive. Cadmium, lead, mercury, hexavalent, chromium, PBB and PBDE are not used.

Customizable for several contacts.
Ask about details.

AXR(3/5)

ORDERING INFORMATION

1. System connectors ultra-low profile type receptacle

AXR

3: System connectors ultra-low profile type

<Composite function>

2: Coaxial, with battery terminal

5: With battery terminal

<No. of signal wire>

2: SIL 18 contacts

3: SIL 22 contacts

4: SIL 24 contacts

<No. of coaxial pole>

7: Without coaxial

8: 1 pin

<On board/board cutting>

1: On board type

4: Board cutting type

<Packing>

P: Embossed tape and paper reel × 2

V: Embossed tape and paper reel × 5

2. I/O connectors for portable equipment receptacle

AXR

5: I/O connectors for portable equipment

<Receptacle>

1: Receptacle

<No. of signal wire>

18: SIL 18 contacts

22: SIL 22 contacts

24: SIL 24 contacts

26: SIL 26 contacts

50: SIL 50 contacts

<Function>

	A type/B type	On board/ board cutting/ board mounting	Positioning boss
4	B type	On board	Not available
8	A type		

<Packing>

P: Embossed tape and paper reel × 2

3. System connectors ultra-low profile type plug

AXR

3: System connectors ultra-low profile type

<Plug>

0: Plug

<No. of signal wire>

2: SIL 18 contacts

3: SIL 22 contacts

4: SIL 24 contacts

5: SIL 26 contacts

6: SIL 50 contacts

<On board/board cutting/No. of coaxial pin>

	On board/board cutting	No. of coaxial pin
4	On board	Without
7	Board cutting	1 pin
9		Without

<Function>

	Cable connection type/ Board mounting type	A type/B type	Shield
0	Cable connection type	A type	Available
1		B type	
3	Cable connection type	A type	Not available
4		B type	
5	Board mounting type	A type	Available
A		B type	

<Packing>

Nil: Embossed tape and paper reel × 2

* Board mounting type only.

4. I/O connectors for portable equipment plug

AXR

5: I/O connectors for portable equipment

<Plug, A type/B type>

2: Plug A type

<No. of signal wire>

5: SIL 50 contacts

<Applicable cable dia.>

6: 5.5mm dia.

7: 6.2mm dia.

<Shield>

S: With shield

Note) Applicable for cable connection type 50 contacts

RECEPTACLE AND PLUG COMPATIBILITY TABLE

1. Signal terminals 18 to 50 contacts

1) Plug (Cable connection type)

• Plug



A type

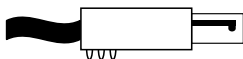

Design side

- Corresponds to on board mounting type receptacle 50 contacts

B type

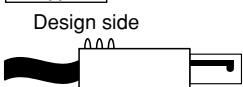

Design side

- Corresponds to board cutting type receptacle 18 and 22 contacts
- Corresponds to on board mounting type receptacle 18, 22, 24 and 26 contacts

• Combination table

Plug (A type)-Receptacle (A type) are mated

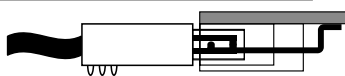

No. of signal terminals	On board/board cutting	Receptacle composite function	Part No. (Plug)	Part No. (Receptacle)
50 contacts	On board mounting type	Signal terminals only	AXR5256S	AXR51508P
			AXR5257S	

Plug (B type)-Receptacle (A type) are mated

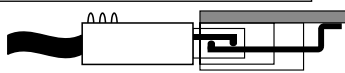

No. of signal terminals	On board/board cutting	Receptacle composite function	Part No. (Plug)	Part No. (Receptacle)
18 contacts	Board cutting type	Coaxial 1 pin	AXR30274	AXR32284P
22 contacts		Battery terminal 4 contacts		
18 contacts	On board mounting type	Battery terminal 4 contacts	AXR30394	AXR35374P
22 contacts		Signal terminals only	AXR30244	AXR51188P
		Signal terminals only	AXR30341 AXR30344	AXR51228P
22 contacts		Battery terminal 3 contacts	AXR30341 AXR30344	AXR35371P
24 contacts		Signal terminals only	AXR30444	AXR51248P
24 contacts		Battery terminal 3 contacts	AXR30444	AXR35471V
26 contacts	Signal terminals only	AXR30541	AXR51268P	

Plug (B type)-Receptacle (B type) are mated

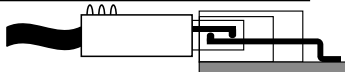

No. of signal terminals	On board/board cutting	Receptacle composite function	Part No. (Plug)	Part No. (Receptacle)
22 contacts	On board mounting type	Signal terminals only	AXR30341 AXR30344	AXR51224P

• Receptacle



A type

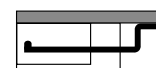

- Board cutting type 18 and 22 contacts
- On board mounting type 18, 22, 24, 26 and 50 contacts

B type

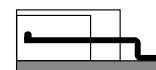

- On board mounting type 22 contacts

Plug (Board mounting type)

• Plug



A type



- Corresponds to on board mounting type receptacle 22 contacts

B type



- Corresponds to on board mounting type receptacle 22, 26 and 50 contacts

• Combination table

Plug (A type)-Receptacle (A type) are mated



No. of signal terminals	On board/board cutting	Receptacle composite function	Part No. (Plug)	Part No. (Receptacle)
22 contacts	On board mounting type	Signal terminals only	AXR3034A	AXR51228P
		Battery terminal 3 contacts	AXR3034A	AXR35371P

Plug (A type)-Receptacle (B type) are mated

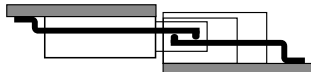

No. of signal terminals	On board/board cutting	Receptacle composite function	Part No. (Plug)	Part No. (Receptacle)
22 contacts	On board mounting type	Signal terminals only	AXR3034A	AXR51224P

Plug (B type)-Receptacle (A type) are mated



No. of signal terminals	On board/board cutting	Receptacle composite function	Part No. (Plug)	Part No. (Receptacle)
26 contacts	On board mounting type	Signal terminals only	AXR30545	AXR51268P
50 contacts			AXR30645	AXR51508P

Plug (B type)-Receptacle (B type) are mated

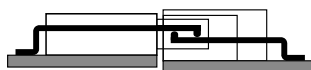

No. of signal terminals	On board/board cutting	Receptacle composite function	Part No. (Plug)	Part No. (Receptacle)
22 contacts	On board mounting type	Signal terminals only	AXR30345	AXR51224P

• Receptacle



A type



- On board mounting type 22, 26 and 50 contacts

B type



- On board mounting type 22 contacts

AXR(3/5)

3. Information about A and B types

• Plug

1) Cable connection type

- When the contact side and design side,
- face in the same direction it is A Type
 - face in opposite directions it is B Type

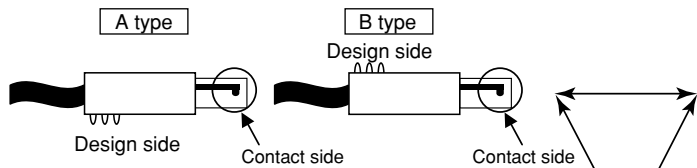

2) Board mounting type

- When the contact side and mounting side,
- face in the same direction it is A Type
 - face in opposite directions it is B Type

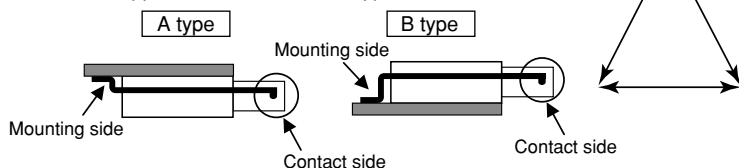

• Receptacle

- When the contact side and mounting side,
- face face in opposite directions it is A Type
 - face the in the same direction it is B Type

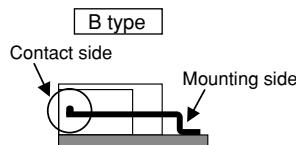
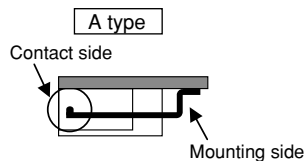

PRODUCT TYPES

1. Receptacle

No. of signal terminals	Type	No. of coaxial	No. of battery terminal	Part No.	Packing quantity	
					Inner carton (1 reel)	Outer carton
18 contacts	Board cutting type (A type)	1	4 contacts	AXR32284P	700 pcs.	1,400 pcs.
	On board mounting type (A type)	None	None	AXR51188P	1,000 pcs.	2,000 pcs.
22 contacts	Board cutting type (A type)	None	4 contacts	AXR35374P	700 pcs.	1,400 pcs.
	On board mounting type (A type)	None	None	AXR51228P	1,000 pcs.	2,000 pcs.
	On board mounting type (A type)	None	3 contacts	AXR35371P	700 pcs.	1,400 pcs.
	On board mounting type (B type)	None	None	AXR51224P	1,000 pcs.	2,000 pcs.
24 contacts	On board mounting type (A type)	None	None	AXR51248P	1,000 pcs.	2,000 pcs.
	On board mounting type (A type)	None	3 contacts	AXR35471V	700 pcs.	3,500 pcs.
26 contacts	On board mounting type (A type)	None	None	AXR51268P	1,000 pcs.	2,000 pcs.
50 contacts	On board mounting type (A type)	None	None	AXR51508P	750 pcs.	1,500 pcs.

Note) For cellular phones and other applications where problems of insertion into the wrong device is possible, the location of the key will be changed for each order. An order number will be set for each separate order.

2. Plug (Cable connection type)

No. of signal terminals	Type	EMI immunity	Part No.	Packing quantity	
				Inner carton	Outer carton
18 contacts	Board cutting type (B type)	Not available	AXR30274	—	600 pcs.
	On board mounting type (B type)	Not available	AXR30244	—	600 pcs.
22 contacts	Board cutting type (B type)	Not available	AXR30394	—	600 pcs.
	On board mounting type (B type)	Available	AXR30341	—	600 pcs.
		Not available	AXR30344	—	600 pcs.
24 contacts	On board mounting type (B type)	Not available	AXR30444	—	600 pcs.
26 contacts	On board mounting type (B type)	Available	AXR30541	—	600 pcs.
	On board mounting type (A type)	Available	AXR5256S (for 5.5 dia. cable)	—	200 pcs.
50 contacts	On board mounting type (A type)	Available	AXR5257S (for 6.2 dia. cable)	—	200 pcs.

Note) For cellular phones and other applications where problems of insertion into the wrong device is possible, the location of the key will be changed for each order. An order number will be set for each separate order.

2. Plug (PC board mounting type)

No. of signal terminals	Type	EMI countermeasure	Part No.	Packing quantity	
				Inner carton	Outer carton
22 contacts	On board mounting type (A type)	Available	AXR3034A	500 pcs.	1,000 pcs.
	On board mounting type (B type)	Available	AXR30345	500 pcs.	1,000 pcs.
26 contacts	On board mounting type (B type)	Available	AXR30545	500 pcs.	1,000 pcs.
50 contacts	On board mounting type (B type)	Available	AXR30645	500 pcs.	1,000 pcs.

SPECIFICATIONS

1. Characteristics

1) Receptacle–Plug (cable connection type)

Item		Specifications				Condition
		18 contacts (with coaxial)	18 (without coaxial) 22, 24 contacts	26 contacts	50 contacts	
Electrical characteristics	Rated Current	Signal contact	0.5 A (1 A can be passed through two terminals connected in series) (Total for all terminals is max. 10 A.)			—
		Battery contact	2 A		—	Characteristic of receptacle alone.
	Contact resistance	Signal contact	Max. 110mΩ (Initial)			Measured based on the milliohm meter measurement method of JIS C 5402, except for the resistance of the cord on the plug side.
		Battery contact	Max. 50mΩ (Initial)		—	Measured based on the milliohm meter measurement method of JIS C 5402, except for the resistance of the terminals on the battery side.
	Insulation resistance		Min. 1,000MΩ (Initial)			Using 500V DC megger (applied for 1 min.)
	Breakdown voltage		150V AC for 1 min.			Rated voltage is applied for one minute and check for short circuit or damage with a detection current of 1 mA.
High frequency characteristics (Coaxial portion)	Nominal impedance	50Ω	—		—	
	Applicable frequency	DC to 2GHz	—		—	
Mechanical characteristics	Lever lock strength	Min. 49N {5kgf}			The plug is pulled off with the connectors mated.	
Lifetime characteristics	Insertion and removal life of plug and receptacle	Mechanical life: 10,000 times Contact resistance after testing: Max. 110 mΩ High frequency characteristics of coaxial portion: Satisfies high frequency characteristics given above	Mechanical life: 10,000 times Contact resistance after testing: Max. 110mΩ	Mechanical life: 5,000 times (mechanical insertion and removal) Contact resistance after testing: Max. 110mΩ	The connectors are connected and disconnected at a rate of 200 times/hour or less.	
Environmental characteristics	Ambient temperature		−35°C to +65°C			No freezing or condensation in low temperatures
	Storage temperature		−40°C to +70°C (The allowable storage temperature is −40°C to +50°C if unopened from original packaging)			No freezing or condensation in low temperatures
	Resistance to soldering heat	Receptacle	Reflow soldering: peak temperature 245°C or less			Surface temperature (shell) from infrared reflow soldering machine
		Plug	Hand soldering: Soldering iron temperature 300°C, 5 sec. or less			—
Unit weight		Receptacle (AXR32284P): 1.01 g Plug (AXR30274): 6.46 g	Receptacle (AXR35371P) 22 contacts: 0.86 g Plug (AXR30341) 22 contacts: 6.18 g	Receptacle (AXR51508P) 50 contacts: 1.42 g Plug (AXR5256S) 50 contacts: 11.1 g	—	

2) Receptacle–Plug (Board mounting type)

Item		Specifications		Condition	
		22, 26, 50 contacts			
Electrical characteristics	Rated current	Signal contact	0.5 A (7 A can be passed through all terminals connected) (The total for 50 terminals is max. 10 A.)		—
	Contact resistance	Signal contact	22 contacts (A type) Max. 110 mΩ (Initial) 22 contacts (B type) Max. 140 mΩ (Initial) 26 contacts (B type) Max. 110 mΩ (Initial) 50 contacts (B type) Max. 110 mΩ (Initial)		Measured based on the milliohm meter measurement method of JIS C 5402
		Insulation resistance		Min. 1,000MΩ (Initial)	
	Breakdown voltage		150 V AC for 1 min.		Rated voltage is applied for one minute and check for short circuit or damage with a detection current of 1 mA.
Lifetime characteristics	Insertion and removal life of plug and receptacle	Mechanical life: 5,000 times Contact resistance after testing: Max. 110 mΩ (Contact resistance after testing satisfies initial value.)		The connectors are connected and disconnected at a rate of 200 times/hour or less.	
Environmental characteristics	Ambient temperature		−35°C to +65°C		No freezing or condensation in low temperatures
	Storage temperature		−40°C to +70°C (The allowable storage temperature is −40°C to +50°C if unopened from original packaging)		No freezing or condensation in low temperatures
	Resistance to soldering heat	Plug	Reflow soldering: peak temperature 245°C or less		Surface temperature (shell) from infrared reflow soldering machine
Unit weight		22 contacts (A type): 1.43 g, 22 contacts (B type): 1.53 g, 26 contacts (B type): 1.48 g, 50 contacts (B type): 2.30 g		—	

Note) Refer to above table for the characteristics of the receptacle.

AXR(3/5)

2. Material and surface treatment

	Portion	Material	Surface
Receptacle	Resin-molding portion	Heat resistant resin (UL94V-0)	—
	Shell	Stainless steel	Cu plating base, Sn plating on surface
	Post/battery contact	Copper alloy	Contact portion: Ni plating on base, Au plating on surface Terminal portion: Ni plating on base, Au plating on surface (except for end of the terminal)
Plug (cable connection type)	Resin-molding portion	Heat resistant resin (UL94V-0) Only bushing is polyurethane resin (UL94HB)	—
	Shell	Stainless steel	—
	Contact	Copper alloy	Contact portion: Ni plating on base, Au plating on surface Signal wire soldering portion: Ni plating on base, Au plating on surface
	Tapping screw	Carbon steel	Rust proofed
	Insulation plate	Phenolic resin or PBT	—
Plug (Board mounting type)	Resin-molding portion	Heat resistant resin (UL94V-0)	—
	Shell	Stainless steel	Cu plating base, Sn plating on surface
	Contact	Copper alloy	Contact portion: Ni plating on base, Au plating on surface Terminal portion: Ni plating on base, Au plating on surface (except for end of the terminal)

DIMENSIONS

mm General tolerance: ± 0.3

1. Signal terminals 18 contacts/Board cutting type

- Receptacle (1 coaxial/battery terminal 4 contacts) (A type)
AXR32284P

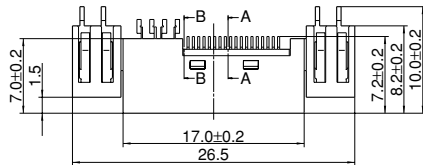

A-A cross section

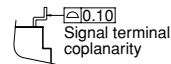

B-B cross section

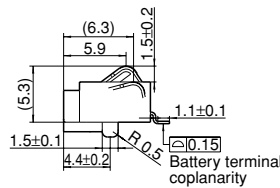
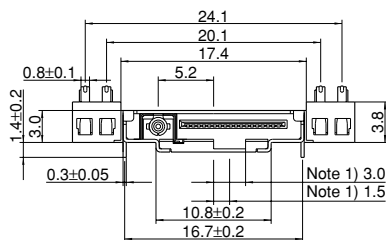
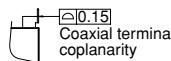

Recommended PC board pattern (TOP VIEW)

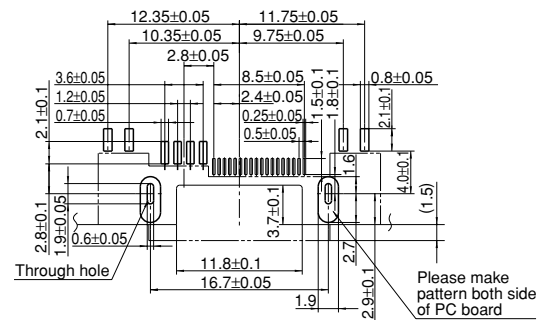

- Notes
1. The position of the cross-manufacturer mating error prevention key, if requested, can be set for each user when the detailed specifications are being decided.
 2. Since product bottom is a metal shell, do not make pattern circuits (to prevent shorting).

- Plug (cable connection type) (B type)
(assembled condition)
AXR30274

mm General tolerance: ± 0.3

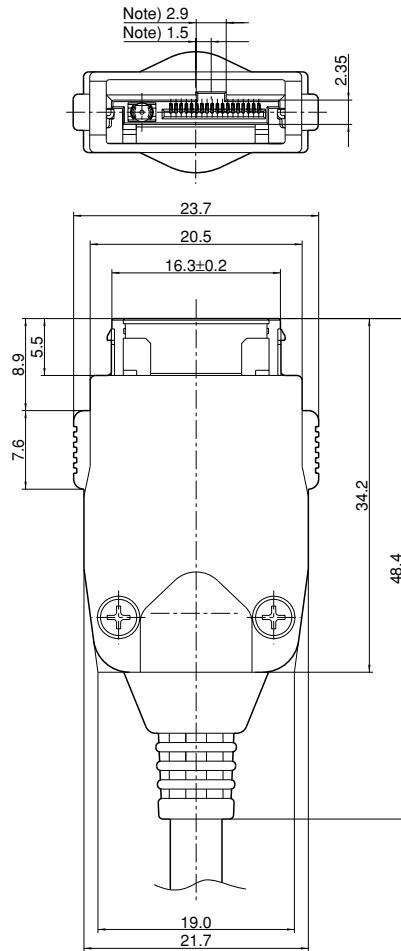

Note) The position of the cross-manufacturer mating error prevention key, if requested, can be set for each user when the detailed specifications are being decided.

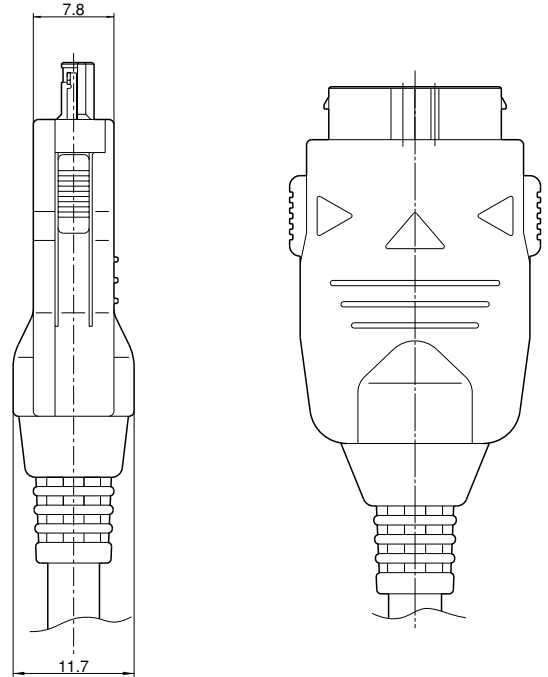

Circuit diagram of coaxial portion

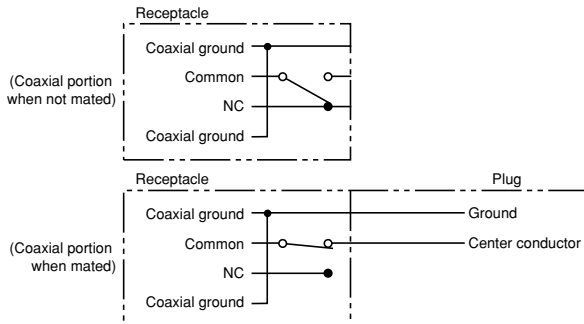

No. of signal terminal (A type)

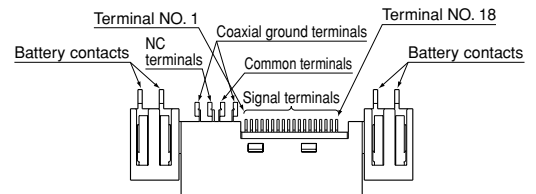

2. Signal terminals 18 contacts/On board mounting type

mm General tolerance: ± 0.3

- Receptacle (A type)
AXR51188P

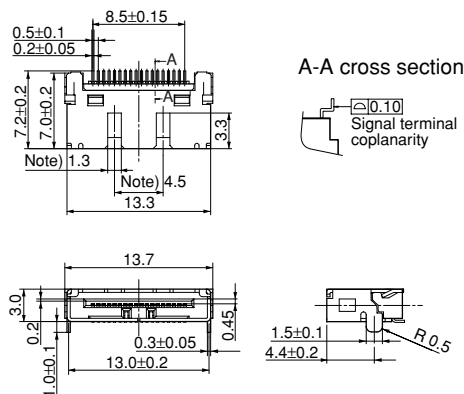

Recommended PC board pattern (TOP VIEW)

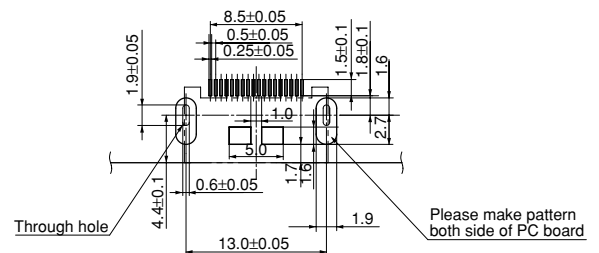

Notes) 1. The position of the cross-manufacturer mating error prevention key, if requested, can be set for each user when the detailed specifications are being decided.
2. Since product bottom is a metal shell, do not make pattern circuits (to prevent shorting).

AXR(3/5)

- Plug (cable connection type) (B type)
(assembled condition)
AXR30244

mm General tolerance: ± 0.3

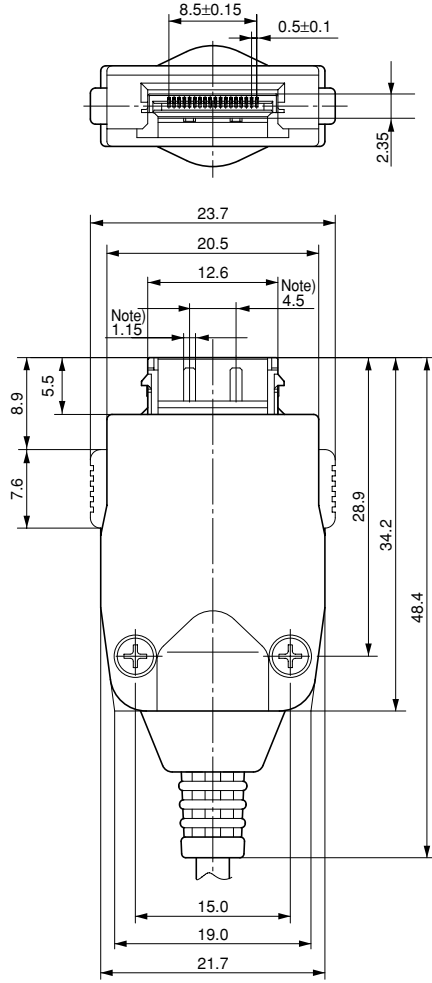

Note) The position of the cross-manufacturer mating error prevention key, if requested, can be set for each user when the detailed specifications are being decided.

No. of signal terminal (A type)

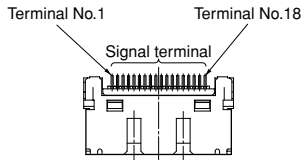

3. Signal terminals 22 contacts/Board cutting type

mm General tolerance: ± 0.3

- Receptacle (with battery terminal 4 contacts) (A type)
AXR35374P

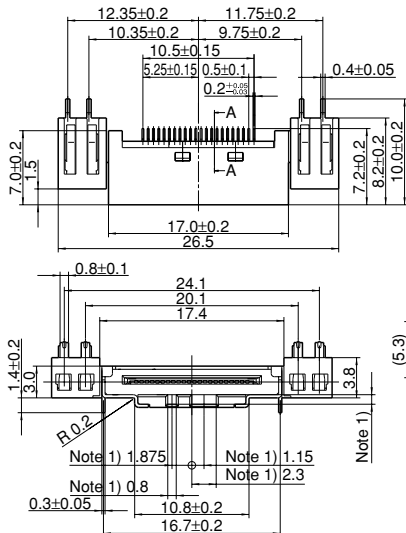

A-A cross section

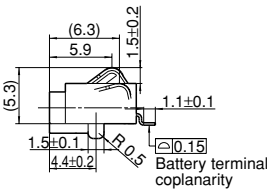
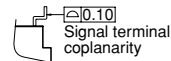

Recommended PC board pattern (TOP VIEW)

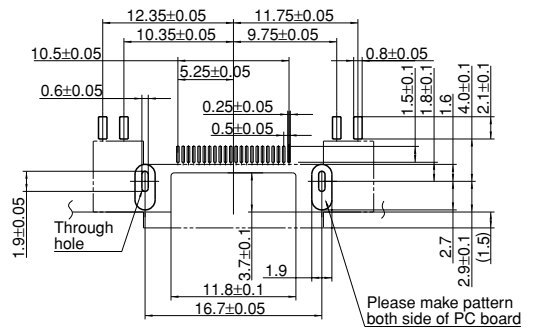

- Notes
1. The position of the cross-manufacturer mating error prevention key, if requested, can be set for each user when the detailed specifications are being decided.
 2. Since product bottom is a metal shell, do not make pattern circuits (to prevent shorting).

- Plug (cable connection type) (B type)
(assembled condition)
AXR30394

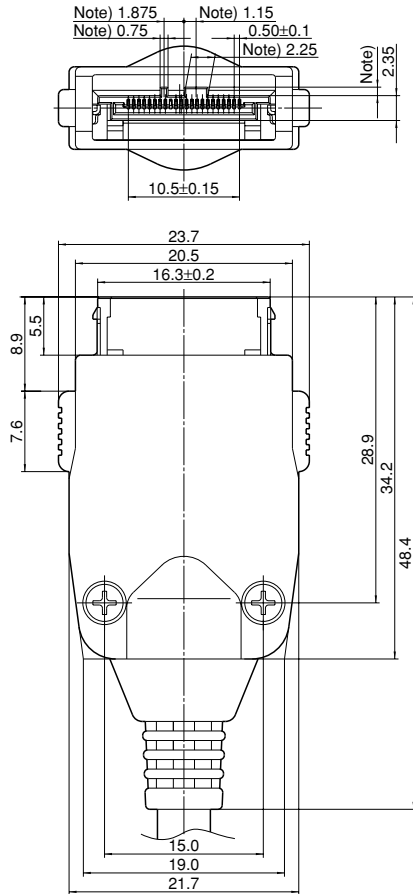

Note) The position of the cross-manufacturer mating error prevention key, if requested, can be set for each user when the detailed specifications are being decided.

No. of signal terminal (A type)

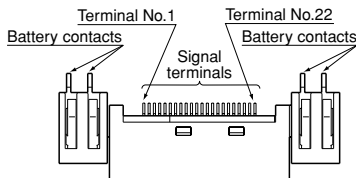

4. Signal terminals 22 contacts/On board mounting type

- Receptacle (A type)
AXR51228P

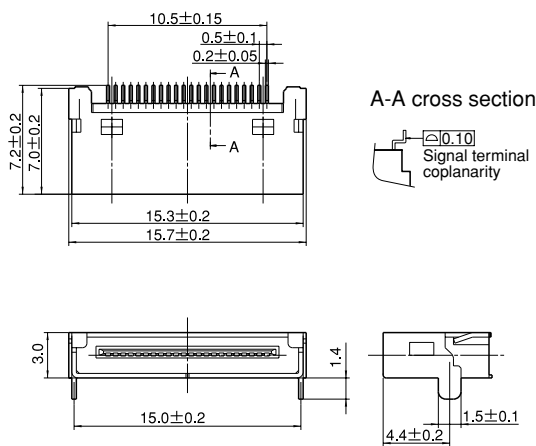

Recommended PC board pattern (TOP VIEW)

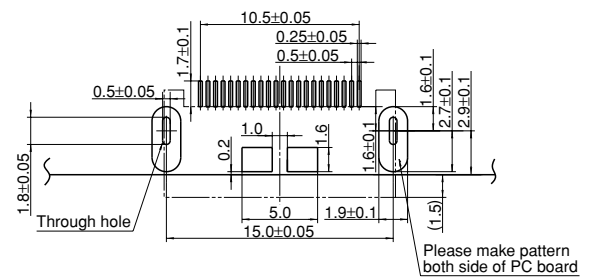

Notes) 1. The position of the cross-manufacturer mating error prevention key, if requested, can be set for each user when the detailed specifications are being decided.
2. Since product bottom is a metal shell, do not make pattern circuits (to prevent shorting).

AXR(3/5)

• Receptacle (B type)
AXR51224P

mm General tolerance: ± 0.3

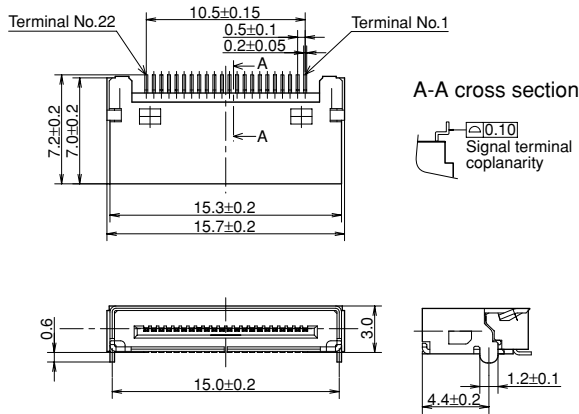

Recommended PC board pattern
(TOP VIEW)

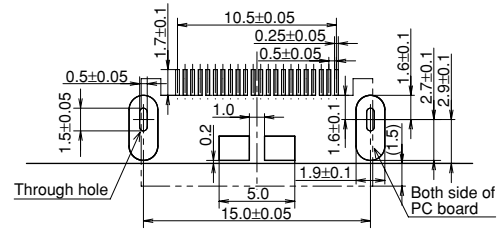

- Notes 1. The position of the cross-manufacturer mating error prevention key, if requested, can be set for each user when the detailed specifications are being decided.
2. Since product bottom is a metal shell, do not make pattern circuits (to prevent shorting).

• Receptacle (battery terminal 3 contacts) (A type)
AXR35371P

mm General tolerance: ± 0.3

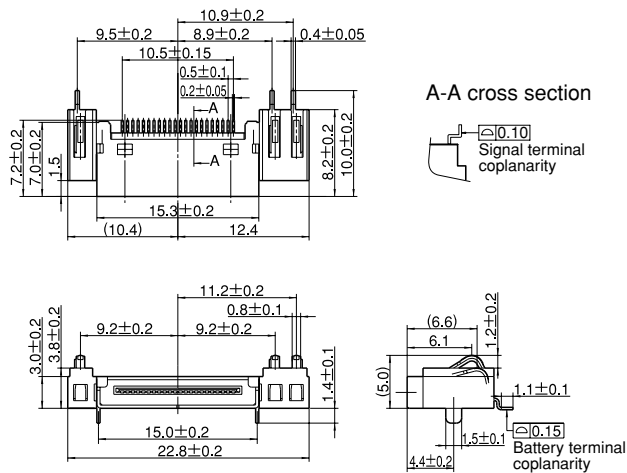

Recommended PC board pattern
(TOP VIEW)

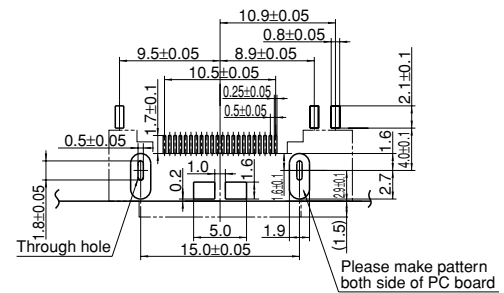

- Notes 1. The position of the cross-manufacturer mating error prevention key, if requested, can be set for each user when the detailed specifications are being decided.
2. Since product bottom is a metal shell, do not make pattern circuits (to prevent shorting).

No. of signal terminal (A type)

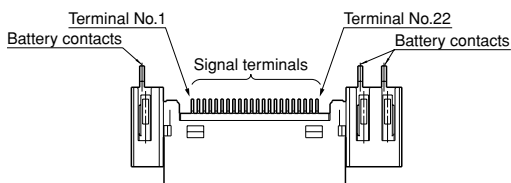

- Plug (cable connection type) (B type)
(assembled condition)
AXR30341
AXR30343

mm General tolerance: ± 0.3

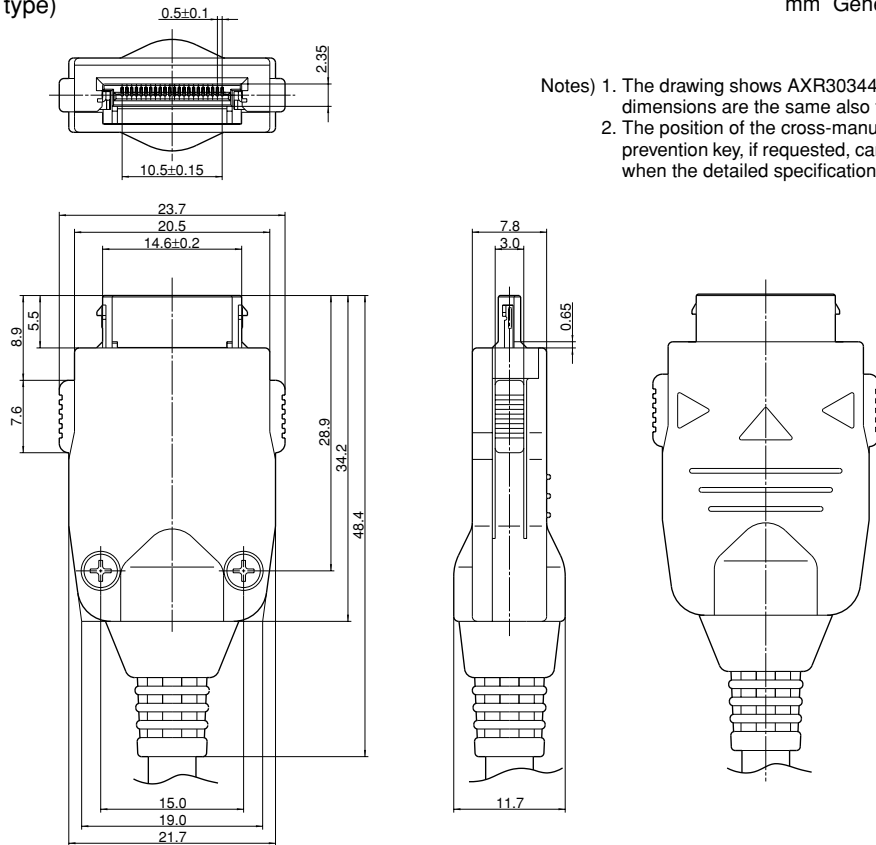

- Notes
1. The drawing shows AXR30344. (External dimensions are the same also for AXR30341.)
 2. The position of the cross-manufacturer mating error prevention key, if requested, can be set for each user when the detailed specifications are being decided.

- Plug (Board mounting type) (B type)
AXR30345

mm General tolerance: ± 0.3

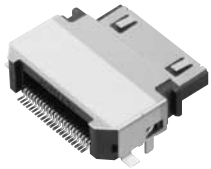

Recommended PC board pattern (TOP VIEW)

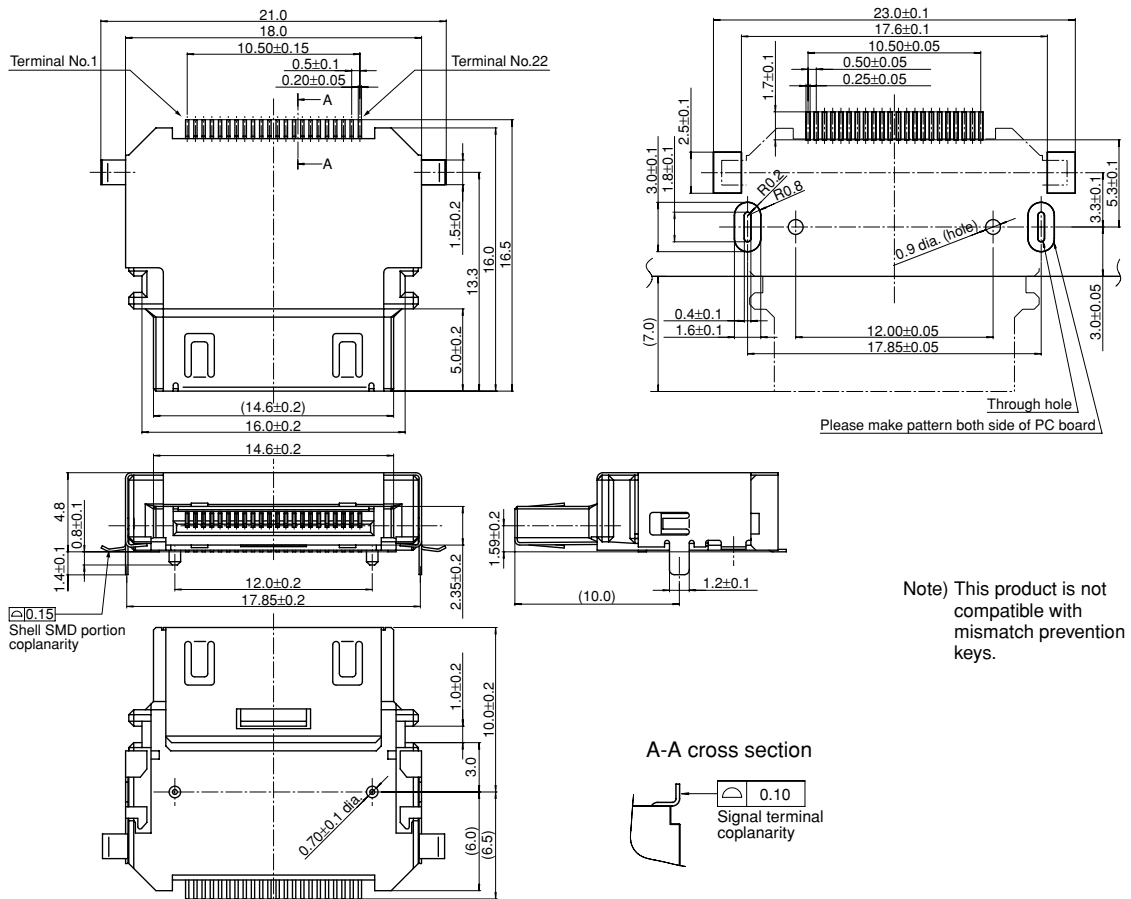

AXR(3/5)

6. Signal terminals 26 contacts/On board mounting type

mm General tolerance: ± 0.3

- Receptacle (A type)
AXR51268P

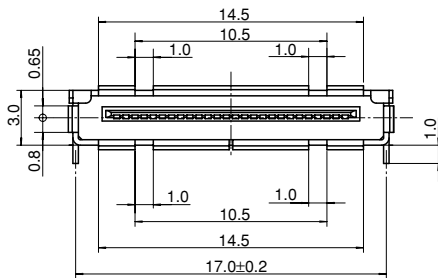
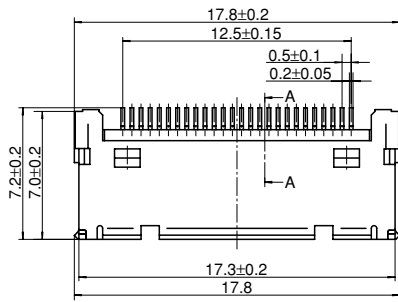

Recommended PC board pattern (TOP VIEW)

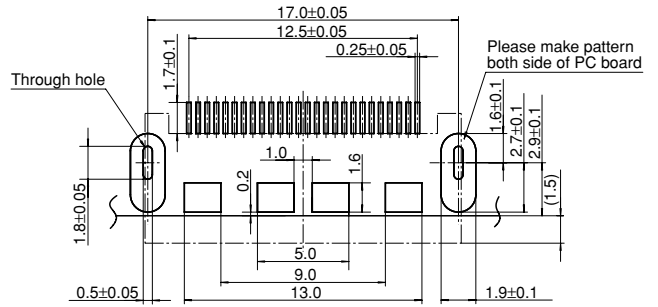

Note) Since product bottom is a metal shell, do not make pattern circuits (to prevent shorting).

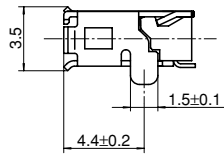

A-A cross section

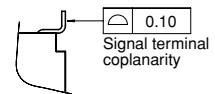

- Plug (cable connection type) (B type)
(assembled condition)
AXR30541

mm General tolerance: ± 0.3

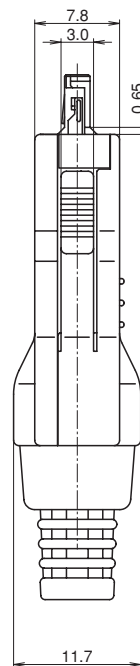
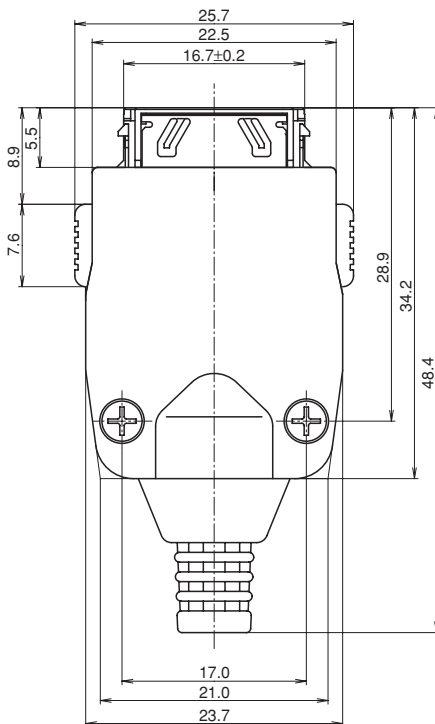
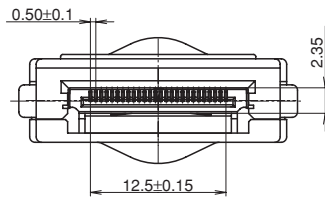

Note) This product is not compatible with mismatch prevention keys.

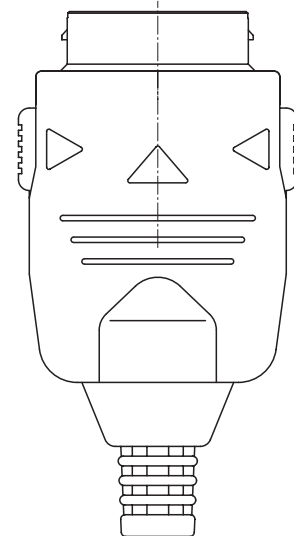

• Plug (Board mounting type) (B type)
AXR30545

mm General tolerance: ± 0.3

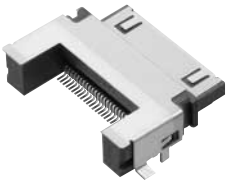

Recommended PC board pattern
(TOP VIEW)

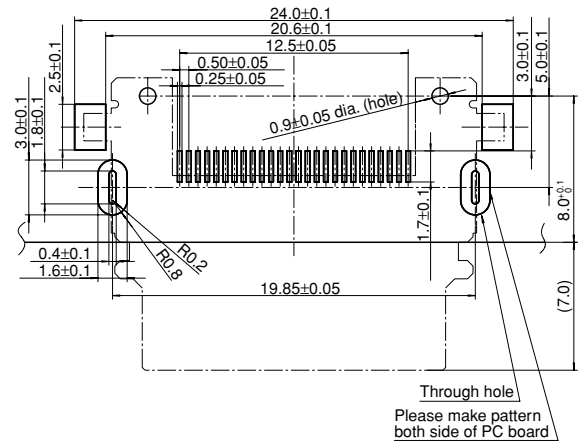

Note) This product is not compatible with mismatch prevention keys.

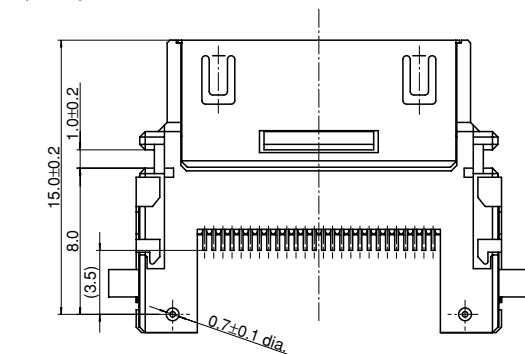
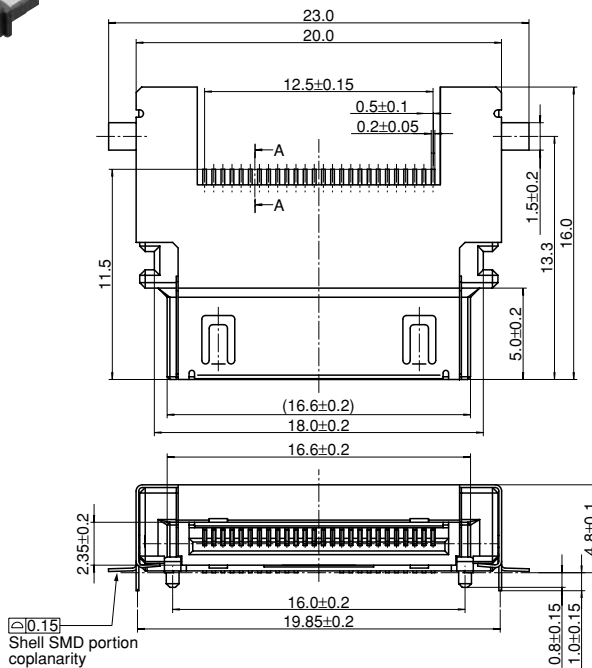
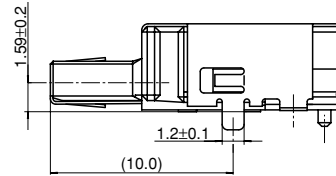

A-A cross section

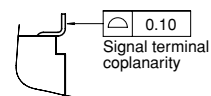

No. of signal terminal (A type)

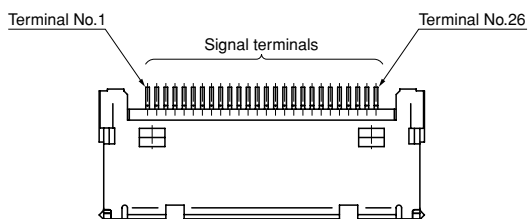

AXR(3/5)

7. Signal terminals 50 contacts/On board mounting type

mm General tolerance: ± 0.3

- Receptacle (A type)
AXR51508P

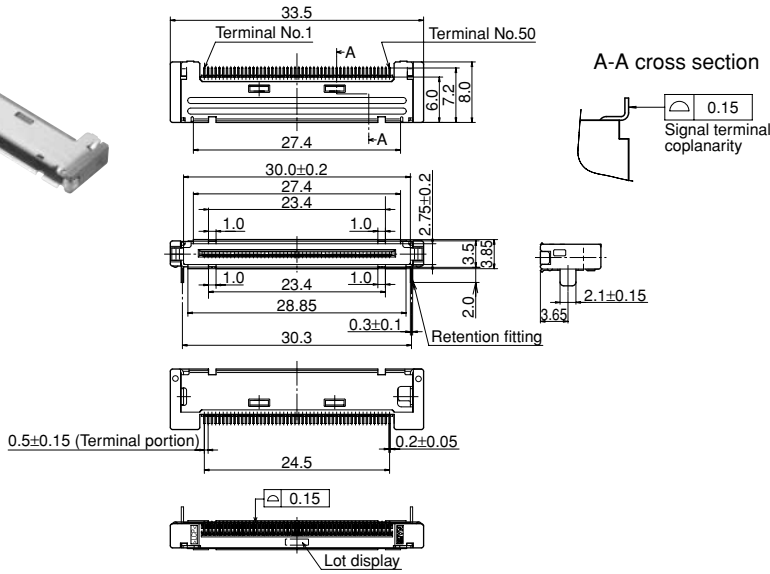

Recommended PC board pattern (TOP VIEW)

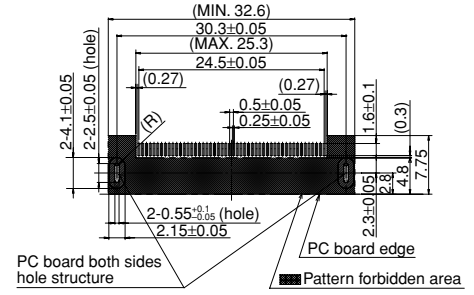

Notes

1. The values in parenthesis are reference dimensions.
2. To reinforce the shell portion of the receptacle, have the shell guided by the casing in some way. The gap between the device casing and receptacle should be constructed to be very small, for example, under 0.1 mm.
3. The dimensions of the cross-manufacturer mating error prevention key, if requested, can be set for each user.

- Plug (cable connection type) (A type)
(assembled condition)

mm General tolerance: ± 0.3

AXR5256S
AXR5257S

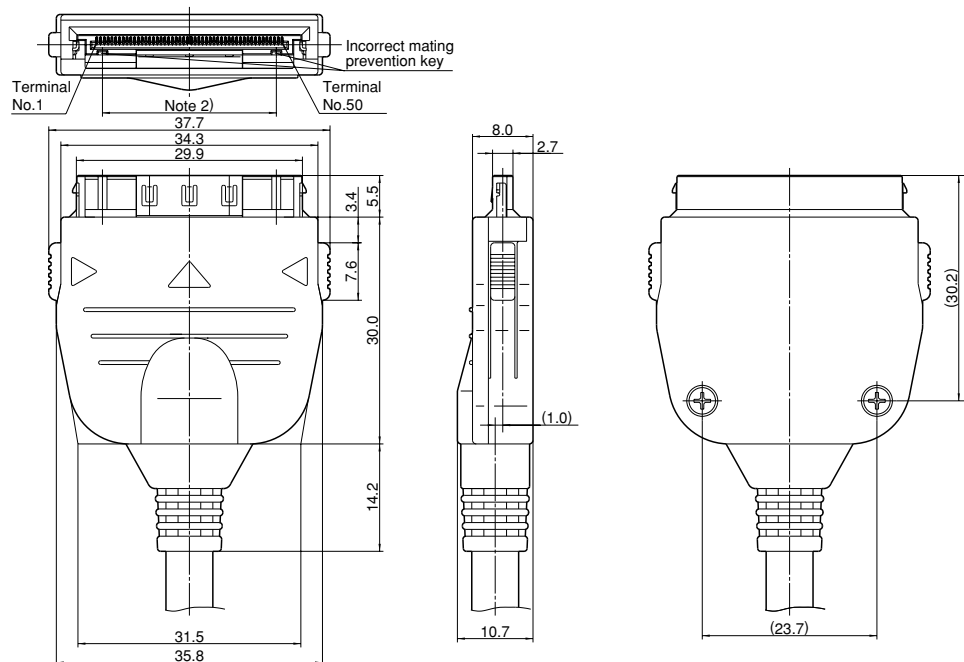

Notes

1. The values in parenthesis are reference dimensions.
2. The dimensions of the cross-manufacturer mating error prevention key, if requested, can be set for each user.

• Plug (Board mounting type)
AXR30645

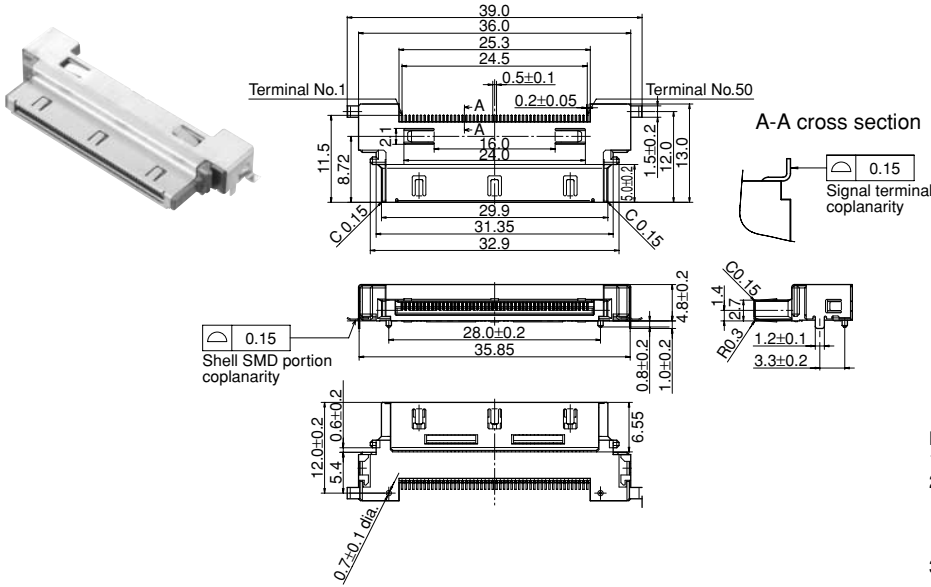

Recommended PC board pattern
(TOP VIEW)

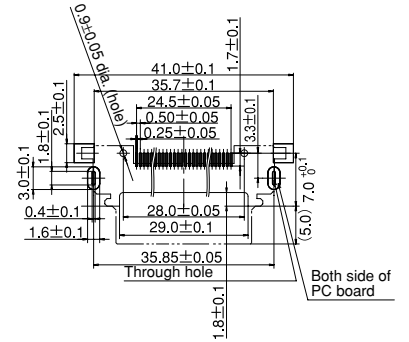

Notes)

1. The values in parenthesis are reference dimensions.
2. To reinforce the shell portion of the receptacle, have the shell guided by the casing in some way. The gap between the device casing and receptacle should be constructed to be very small, for example, under 0.1 mm.
3. The dimensions of the cross-manufacturer mating error prevention key, if requested, can be set for each user.

APPLICATIONS

Products can be made to match your applications, so please contact us if necessary.

1. For cdma-One
2. SMD type with retention fitting
3. With battery and charging terminals
4. With compact battery terminal



5. Difference in battery terminal number



6. A type products (18, 22, 24 and 26 contacts)
B type products (50 contacts)



AXR(3/5)

EMBOSSED TAPE DIMENSIONS (unit: mm)

- Tape dimensions (Conforming to JIS C 0806, 1995. However, some tapes have mounting hole pitches that do not comply with the standard.)

- Reel dimensions (Conforming to JIS C 0806, 1995)

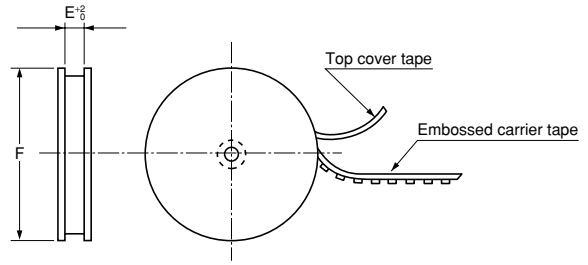
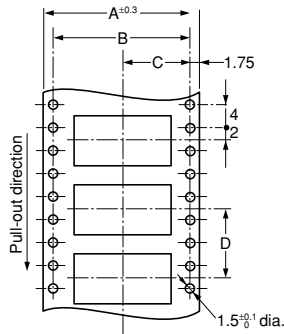

1. Receptacle

	A	B	C	D	E	F	Quantity per reel
Ultra low profile type system connector 18, 22 and 24 contacts	44.0	40.4	20.2	16.0	44.4	370 dia.	700
I/O connector for portable equipment 18, 22, 24 and 26 contacts	32.0	28.4	14.2	16.0	32.4	370 dia.	1,000
I/O connector for portable equipment 50 contacts	44.0	40.4	20.2	16.0	44.4	370 dia.	750

2. Plug (PC board mounting type)

	A	B	C	D	E	F	Quantity per reel
22 and 26 contacts	44.0	40.4	20.2	24.0	44.4	370 dia.	500
50 contacts	56.0	52.4	26.2	24.0	56.4	370 dia.	500

- Connector orientation with respect to direction of progress of embossed tape

Direction of tape progress	Type	Ultra low profile type Receptacle	I/O connector for portable equipment Receptacle	Plug (Board mounting type)
↓				

Regarding general notes, please refer to page 14.

For other details, please verify with the product specification sheets.